



# LED Pro Line Panel

## Product Specifications



TCP's LED Pro Line Panel luminaire features back-lit technology with a robust construction that still offers a slim, low profile with beautiful full-panel diffusion and superior uniformity. These energy-efficient luminaires offer a cost-effective solution to maximize energy savings and take advantage of potential utility rebates where applicable.

Applications: T-bar Grid Ceilings

## Reasons to choose the LED Pro Line Panel from TCP

- Superior energy efficiency compared to fluorescent alternatives, providing instant energy savings and potential rebate ability
- Long 50,000 hour rated life significantly reduces maintenance labor and material costs
- Excellent color consistency and high CRI enhance color of focal point while maintaining uniformity throughout lighting installation
- Mercury-free construction is great for all environments
- Fits standard 1" and 9/16" T-bar grid ceilings
- Utilizes back-lit technology for full diffusion with excellent uniformity
- Slim, low-profile design and lightweight for easy handling

## Ideal Applications

- Office
- Retail Stores
- Schools
- Hospitality
- Restaurants
- Healthcare

## Fast, easy installation with TCP Quick Connet Wiring

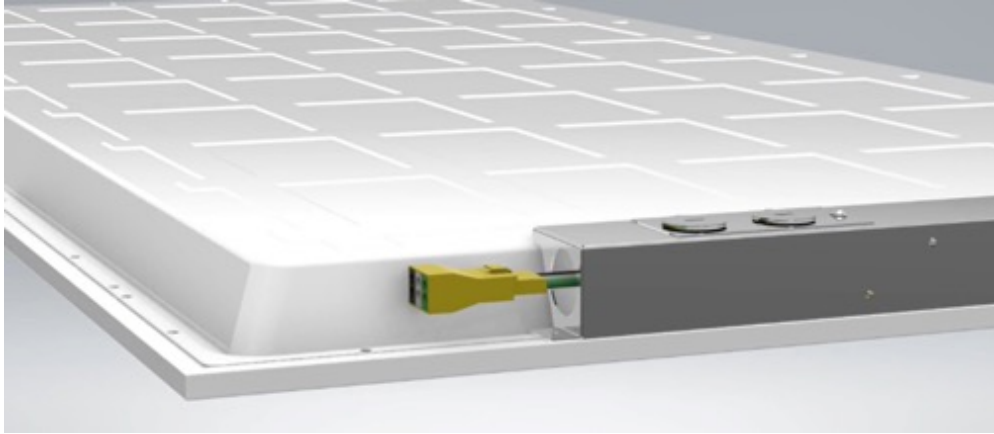

6 node prewired connector included standard.

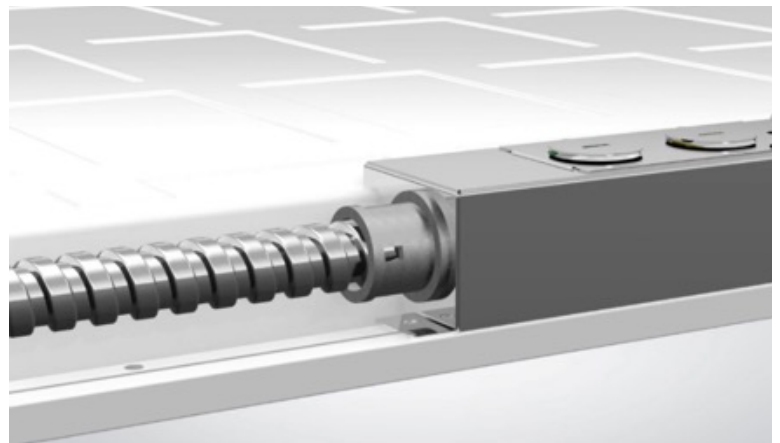
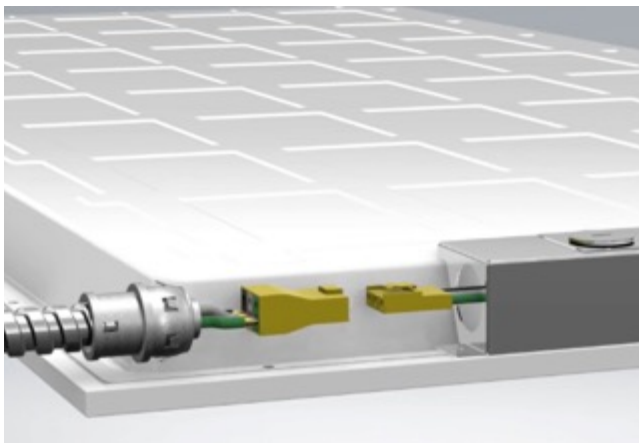

## Install like a PRO with TCP's new Pro Line Panel!

- Time is money - Two-step wiring system reduces wiring install time by 75%
- Daisy Chain ready - Included 6-node connector allows for fast daisy chaining
- Controls? No problem - 0-10V lines included in driver compartment

Scan me to see the PLP in action!



## Specifications

Input Line Voltage .....	120-277 VAC
Input Line Frequency (Hz) .....	50/60Hz
Wattage (W)	
2'x2' .....	38W (Wattage Selectable to 38W/29W/23W)
2'x4' .....	46W (Wattage Selectable to 46W/39W/29W)
Lumens (L)	
2'x2' .....	4200L
2'x4' .....	5100L
Lumens per Watt (LPW).....	>110 LPW
Rated Life.....	50,000 hours
Minimum Starting Temperature .....	-20°C
Maximum Operating Temperature.....	40°C
CRI .....	>80
Power Factor .....	>90%
THD.....	<20%
Ratings .....	UL/cUL damp location rated, IC rated, IP20, DLC Standard 5.1
Controls.....	0-10V dimming (standard)

2'x2'



2'x4'



2' x 2' Pro Line Panel

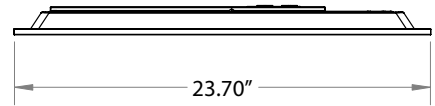
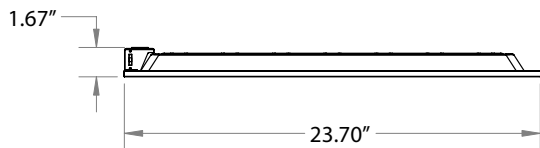

2' x 4' Pro Line Panel

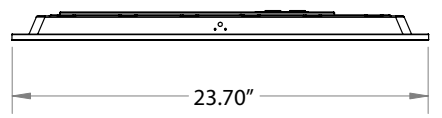
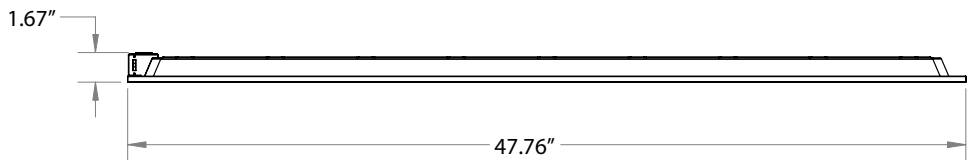

## Applications

TCP LED Pro Line Panel Luminaires are cost-effective, high-efficiency alternatives to traditional T5, T8 and T12 linear fluorescent troffers. Featuring a slim, low-profile design, our LED Pro Line Panel Luminaires use back-lit technology to deliver full panel diffusion and superior uniformity that meets or exceeds the output from edge-lit panels. Applications include offices, schools, retail locations, healthcare, hospitality and other T-grid and commercial ceilings.

## Construction

- Rectangular white frame
- Lens: frosted white diffuser
- IP20 rated
- IC rated for direct contact with insulation
- Designed for easy drop into T-bar grid ceilings
- T-Bar grid clips included standard

## Electrical

- UL/cUL damp location rated
- 0-10V dimming driver (standard)
- LED driver with integrated junction box
- System rated for long 50,000 hour life

## Optics

- Back-lit technology provides even, uniform lighting
- 120° beam angle
- Frosted diffuser for reduced glare and aesthetic appeal
- Meets or exceeds the look and performance of edge-lit panels

Item Number	
Notes	Type



### Listings

UL/cUL Listed  
IC Rated  
RoHS Compliant  
DLC 5.1 Standard

### Lumen Maintenance

L70 > 54,000 hours

### Warranty

Five year limited warranty against defects in manufacturing.

ITEM NUMBER	SIZE	WATTAGE <sup>1,2</sup>	VOLTAGE	LUMENS	COLOR TEMPERATURE
PLP2UZDA1CCT	2' x 2'	38W (Wattage Selectable to 38W/29W/23W)	120V-277V	4200L	3500K/4100K/5000K Selectable
PLP2UZDA130K PLP2UZDA135K PLP2UZDA141K PLP2UZDA150K					3000K 3500K 4100K 5000K

<sup>1</sup> Approximate lumen output. Actual performance may vary based on CCT, options selected and end user application.

<sup>2</sup> Actual wattage may differ by +/- 5%; when operating between 120-277V +/- 10%.

### Accessories:

Item Number	Description
YHANGER6PK	Y FIT CABLE HANGER 6 PACK (ONE PACK HANGS 3 PANELS)
DTSK2	SURFACE MOUNT KIT FOR 2X2 PANEL
DTFLK2	RECESS MOUNT FLANGE KIT FOR 2X2 PANEL

For the most up-to-date specs and warranty information, please visit [www.tcpi.com](http://www.tcpi.com)

## Applications

TCP LED Pro Line Panel Luminaires are cost-effective, high-efficiency alternatives to traditional T5, T8 and T12 linear fluorescent troffers. Featuring a slim, low-profile design, our LED Pro Line Panel Luminaires use back-lit technology to deliver full panel diffusion and superior uniformity that meets or exceeds the output from edge-lit panels. Applications include offices, schools, retail locations, healthcare, hospitality and other T-grid and commercial ceilings.

## Construction

- Rectangular white frame
- Lens: frosted white diffuser
- IP20 rated
- IC rated for direct contact with insulation
- Designed for easy drop in T-bar grid ceilings
- T-bar grid clips included as standard

## Electrical

- UL/cUL damp location rated
- 0-10V dimming driver (standard)
- LED driver with integrated junction box
- System rated for long 50,000 hour life

## Optics

- Back-lit technology provides even, uniform lighting
- 120° beam angle
- Frosted diffuser for reduced glare and aesthetic appeal
- Meets or exceeds the look and performance of edge-lit panels

Item Number	
Notes	Type



### Listings

UL/cUL Listed  
IC Rated  
RoHS Compliant  
DLC 5.1 Standard

### Lumen Maintenance

L70 > 54000 hours

### Warranty

Five year limited warranty against defects in manufacturing.

ITEM NUMBER	SIZE	WATTAGE <sup>1,2</sup>	VOLTAGE	LUMENS	COLOR TEMPERATURE
PLP4UZDA2CCT	2' x 4'	46W (Wattage Selectable to 46W/39W/29W)	120V-277V	5100L	3500K/4100K/5000K Selectable
PLP4UZDA230K PLP4UZDA235K PLP4UZDA241K PLP4UZDA250K					3000K 3500K 4100K 5000K

<sup>1</sup>Approximate lumen output. Actual performance may vary based on CCT, options selected and end user application.

<sup>2</sup>Actual wattage may differ by +/- 5%; when operating between 120-277V +/- 10%.

### Accessories:

Item Number	Description
YHANGER6PK	Y FIT CABLE HANGER 6 PACK (ONE PACK HANGS 3 PANELS)
DTSK4	SURFACE MOUNT KIT FOR 2X4 PANEL
DTFLK4	RECESS MOUNT FLANGE KIT FOR 2X4 PANEL

For the most up-to-date specs and warranty information, please visit [www.tcp.com](http://www.tcp.com)

TCP®

325 Campus Dr. | Aurora, Ohio 44202 | P: 800-324-1496 | [tcp.com](http://tcp.com)

©TCP NOV 2022/WF233767



5 YEAR WARRANTY

Not all versions of this product are qualified on the DLC QPL. To view our DLC qualified products, please consult the DLC Qualified Products List at [www.designlights.org/qpl](http://www.designlights.org/qpl).

# TECHNOLOGY CAST IN A BEAUTIFUL LIGHT

For over 20 years, TCP has been designing, developing and delivering energy-efficient lighting into the market. Thanks to our cutting-edge technology and manufacturing expertise, we have shipped billions of high quality lighting products. With TCP, you can count on a lighting product that is designed to meet the needs of the market - that transforms your surroundings and envelopes you in warmth - lighting that generates beauty with every flip of the switch.

Sales:

Date:

Model:

Project:

Rep:

Catalog Number:

Type:

Notes:



For more information on the quality and care TCP can deliver, call us at **800.324.1496** or visit [tcp.com](http://tcp.com)

325 Campus Dr. | Aurora, Ohio 44202 | P: 800.324.1496 | F: 877.487.0516