

LEDVANCE Luminaires

BACKLIT DUAL SELECTABLE PANEL

VALUE CLASS

Application

The LEDVANCE Backlit Panels are a versatile and economical solution for offices, schools, hospitality and retail areas.

Benefits and Features

- Backlit technology that offers even lighting distribution without shadowing
- Color Selectable: 3500K, 4000K and 5000K in the same product
- Wattage/Lumen selectable: three different lumen outputs in the same product
- PMMA lenses that do not yellow over time
- CRI >80
- Energy savings up to 64%
- DLC Listed to maximize rebate opportunities
- EM ready – compatible with the SYLVANIA field installable emergency battery back-up unit (see Accessories for further details)

Electrical

- 120-277V_{AC}
- Power Factor >0.9
- THD <20%
- 0-10V dimmable

Rated Life

- 50,000 hours (L₇₀)

Warranty

- 5-year
- NLB Trusted Warranty Program

Operating Temperature

- -4°F to +122°F (-20°C to +50°C)

Certifications and Listings

- cETLus
- RoHS
- FCC
- TAA
- IC Rated
- DLC
- Damp Rated



Wattage Comparison

Panel Size	Traditional Source	Traditional System Wattage	LED System Wattage	Energy Savings
1x4	2-lamp 28T8	49	30	39%
	2-lamp 32T8	56	30	46%
2x2	3-lamp 17T8	48	30	38%
	2-Ulamp 31T8	56	30	46%
	2-lamp 28T8	49	30	39%
	2-lamp 32T8	56	30	46%
	3-lamp 32T8	75	30	60%
2x4	3-lamp 28T8	64	35	45%
	3-lamp 32T8	75	35	53%
	3-lamp 28T8	64	40	38%
	3-lamp 32T8	75	40	47%
	4-lamp 28T8	97	40	59%
	4-lamp 32T8	112	40	64%
	4-lamp 28T8	97	45	54%
4-lamp 32T8	116	45	61%	



Specification Data

Catalog #	Type
Project	
Comments	
Prepared by	

Ordering Guide

PANELF	3B	S	UNV	D	8	SC7	XX	G	WH	TAA
Product Name	3B = Generation 3B	S = Selectable Wattage	Voltage	Dimming	CRI	Color Temp	Dimensions	Mounting	Color / Finish	Other
PANELF =		035 = 20/30/35	UNV =	D = 0-10V	8 = >80	SC7 = 3500K,	14 = 1x4	G = Grid	WH = White	TAA = TAA
LED Panel		045 = 30/35/45	120-277V	dimming		4000K and 5000K	22 = 2x2			Compliant
							24 = 2x4			

Ordering Information

Item Number	Ordering Abbreviation	Power (W)	Total Fixture Lumens	Input Voltage (V)	Dimming	CRI	Color Temp	DLC	Efficiency (LPW)	Size
62697	PANELF3BS035UNVD8SC714GWH/TAA	20/30/35	2200/3300/3850	120-277V	0-10V	80	3500/4000/5000K	Standard	110	1x4
62698	PANELF3BS035UNVD8SC722GWH/TAA	20/30/35	2200/3300/3850	120-277V	0-10V	80	3500/4000/5000K	Standard	110	2x2
62699	PANELF3BS045UNVD8SC724GWH/TAA	30/35/45	3300/3850/5000	120-277V	0-10V	80	3500/4000/5000K	Standard	110	2x4

Dimmer Compatibility

Brand	Type	Model
Leviton	0-10V	DS710
Leviton	0-10V	IP710
Lutron	0-10V	NTSTV-DV
Lutron	0-10V	NFTV
Lutron	0-10V	DVTV-WH
Legrand	0-10V	H4FBL3PW

Photometric Data

Average Illuminance (FC) at 30" AFF and avg/min uniformity 80/50/20 Reflectances

			8 ft Mounting Height			10 ft Mounting Height			12 ft Mounting Height		
			On Center Fixture Spacing								
			8'x10'	10'x10'	10'x12'	8'x10'	10'x10'	10'x12'	8'x10'	10'x10'	10'x12'
1'x4'	30W	PANELF3BS035UNVD8SC714GWH	54fc/1.5	44fc/1.3	35fc/2.2	52fc/1.6	43fc/1.5	35fc/2.0	50fc/1.7	41fc/1.6	33fc/1.9
2'x2'	35W	PANELF3BS035UNVD8SC722GWH	53fc/1.5	44fc/1.4	35fc/2.4	51fc/1.6	41fc/1.5	34fc/2.1	49fc/1.7	40fc/1.6	33fc/2.0
2'x4'	45W	PANELF3BS045UNVD8SC724GWH	69fc/1.5	57fc/1.3	47fc/2.3	67fc/1.6	55fc/1.4	45fc/2.0	64fc/1.6	53fc/1.6	43fc/1.9

Physical Information

Lamp Description	(A) Length in (mm)	(B) Width in (mm)	(C) Height in (mm)
1x4	12.0 (304)	47.8 (1214)	1.8 (45)
2x2	23.9 (604)	23.9 (604)	1.7 (44)
2x4	23.9 (604)	47.8 (1214)	1.7 (44)

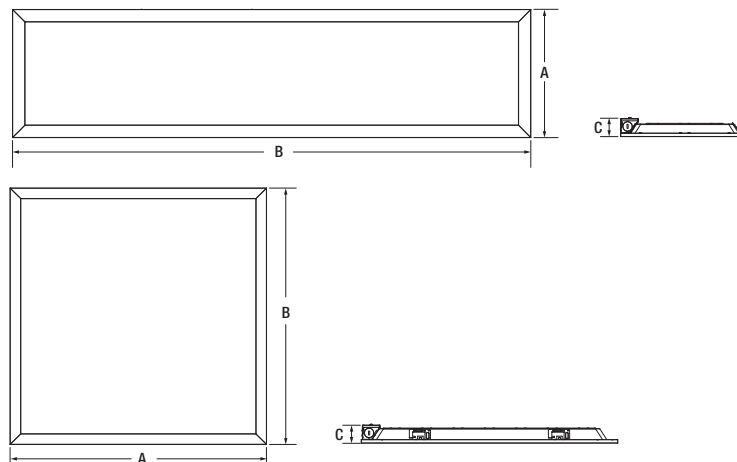

Accessories and Replacement Parts

Item Number	Ordering Abbreviation	Item Description
60888	EMBB1A8WDC	Field installable emergency battery back-up unit
61682	ACCPANELF3AEMBB-BRIDGE2	Metal bridge for installing emergency battery back-up unit to 2x2 and 2x4 panels
61683	ACCPANELF3AEMBB-BRIDGE1	Metal bridge for installing emergency battery back-up unit to 1x4 panels
62064	SMKIT3A/22/WH	Surface Mount Kit for 2x2 Backlit Panel, extruded Aluminum, white finish
62065	SMKIT3A/24/WH	Surface Mount Kit for 2x4 Backlit Panel, extruded Aluminum, white finish
62066	SMKIT3A/14/WH	Surface Mount Kit for 1x4 Backlit Panel, extruded Aluminum, white finish
62067	SPKIT3A	Suspension Kit for Backlit Panels
60457	FK1A14GWH	Flange Kit for 1x4 Panel
60458	FK1A22GWH	Flange Kit for 2x2 Panel
60459	FK1A24GWH	Flange Kit for 2x4 Panel

Metal Bridge

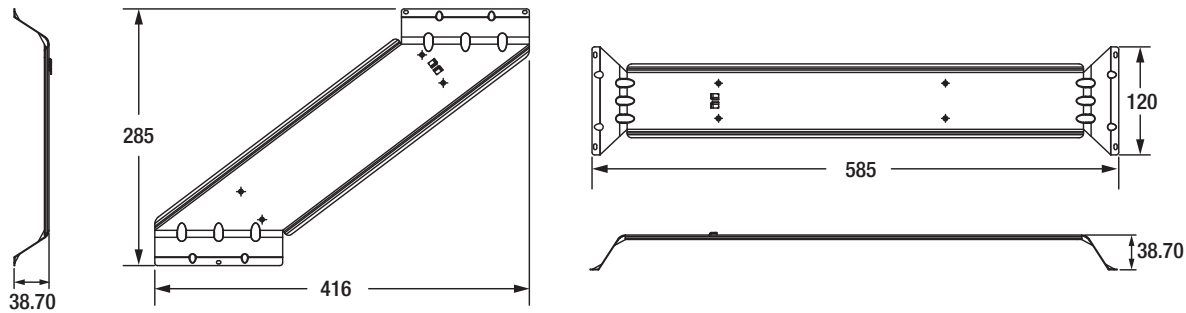

Surface Mount Kit

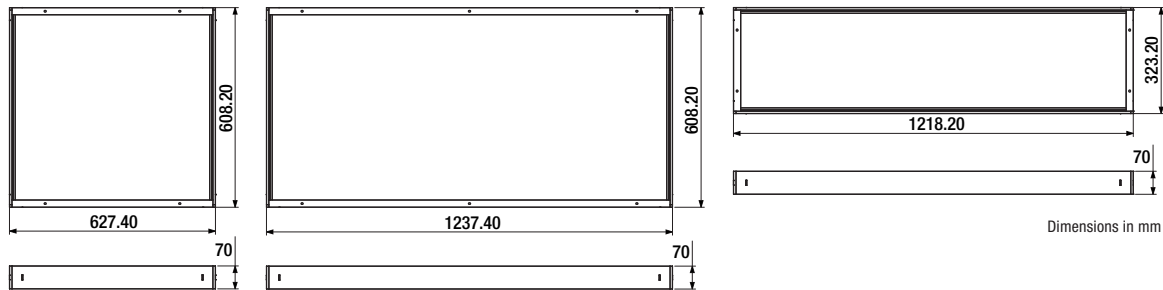

Flange Kit

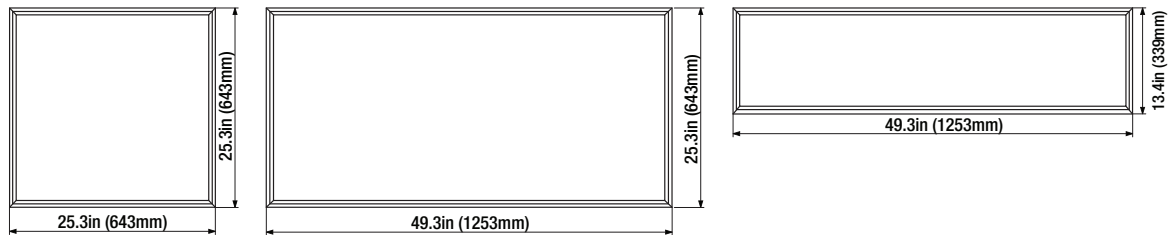

Options Information

Emergency Battery Backup

Emergency Battery Backup: Activates when normal power supply to the fixture fails, providing a minimum of 790 lumens (850 nominal lumens) for at least 90 minutes.

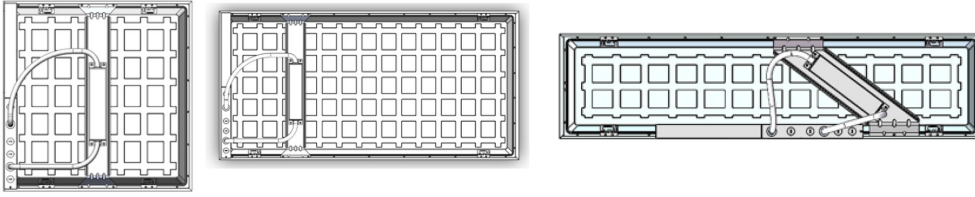

Location of Emergency Test Switch

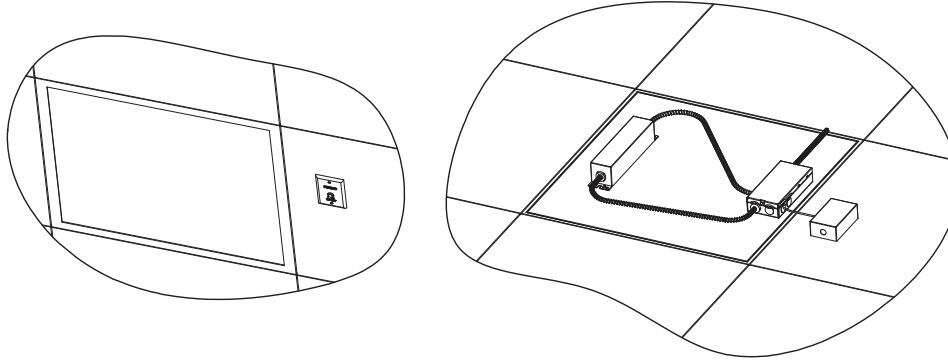

Additional Specifications

- cETLus listed to UL1598 standards
- IC and damp rated

LEDVANCE LLC
200 Ballardvale Street
Wilmington, MA 01887 USA
Phone 1-800-LIGHTBULB (1-800-544-4828)
www.ledvanceUS.com

SYLVANIA and LEDVANCE are registered trademarks.
All other trademarks are those of their respective owners.
Licensee of product trademark SYLVANIA in general lighting.
Specifications subject to change without notice.

 /sylvania  /sylvania