

# 8542-5CCT

120V

Catalog #:		Type
Project:		Date
Prepared by:		

## 6" LED Ultra-Thin Downlight, 5CCT Selectable

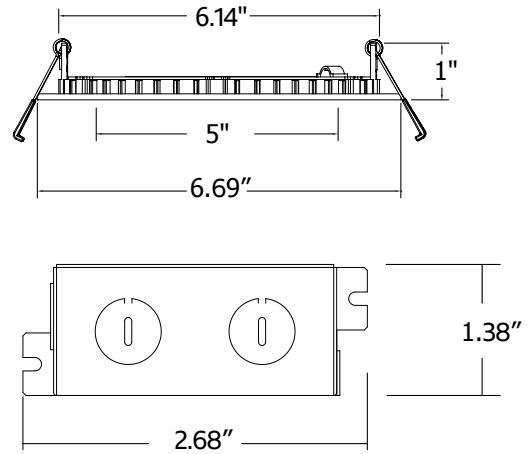

### DESCRIPTION

A versatile LED down light solution with edge-lit technology and an off-board driver allow for an ultra slim profile and flexible mounting options. Installation is a snap with the plenum-rated driver box and linkable connector cable — there is no need for a j-box or recessed housing. The simple spring-loaded retention tabs securely hold each downlight snug to the ceiling.

### DESIGN FEATURES

#### Construction

- Ultra-thin profile
- Durable aluminum construction
- Frosted acrylic lens diffuses glare and maximizes output

#### Electrical

- 120V-60Hz, AC
- Dimmable TRIAC or ELV, 10-100%
- 50,000 hour projected life
- 120° Beam Angle
- Nominal 12.5W | 1055 lms delivered
- 90CRI | 5CCT Selectable: 27K, 3K, 35K, 4K, 5K

#### Installation

- Spring-loaded retention tabs hold downlight snug to ceiling surface, off-board driver/ junction box, poke-in connectors, and linkable connector cable
- IC Rated for direct contact with batt type fiberglass insulation

#### Available Accessories

- **PF-6**: Mounting plate assembly
- **8542PR**: Plastic trim ring

#### Certifications

- cETLus listed for damp location
- IC Rated | Air Tight Rated
- LED Light Source: 5 year limited warranty
- Other Components: 1 year limited warranty

#### ORDERING GUIDE

Example: 8542WH-90-5CCT

Model #	Finish - CRI	CCT
8542	WH-90	
8542	WH:White -90:90CRI	-5CCT Selectable 27K, 3K, 35K, 4K, 5K
Accessories		
PF-6	: Mounting Plate	
8542PR	: Plastic trim ring	

IC  
RATED



LED Light Source  
Other Components

TEL: 800.937.6925 | Fax: 800.207.9509 | [www.rplighting.com](http://www.rplighting.com)

Specifications and dimensions subject to change without notice.

11/11/22



RP | LIGHTING · FANS

8542-5CCT - 6" LED Ultra-Thin Downlight

