

BRM SERIES INDUSTRIAL INFRARED HEATER



IDEAL SPACES

- Wastewater Treatment Plants
- Loading Docks
- Foundries
- Auto or Marine Repair Facilities
- Walkways
- Assembly Areas
- Enclosed Smoking Areas
- Indoor/Outdoor Storage Areas

ENCLOSURE TYPE

- Stainless Steel

ELEMENT TYPE*

- Metal Sheath

REFLECTIVE ANGLE

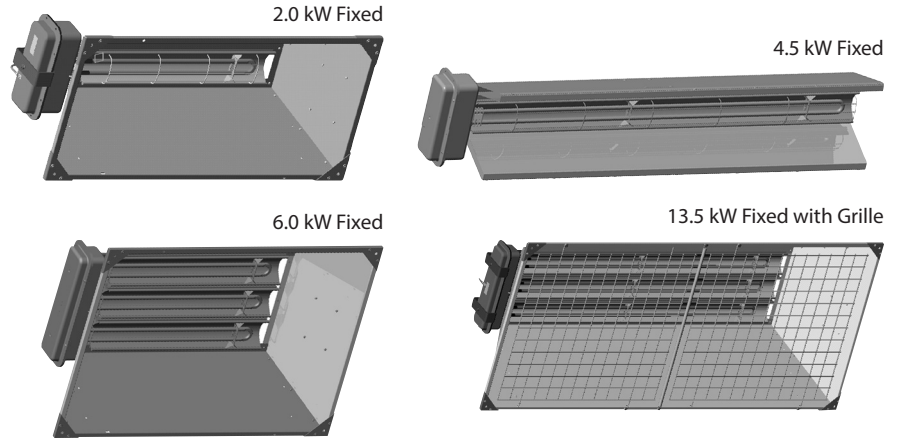

- Ideal for permanent supplemental, spot heating where dependence on air movement is impractical
- High-watt density and industrial design provides a durable source of heat
- Units are rated to be permanently mounted in the horizontal position
- Heavy-duty U-Bend element
- Electric heaters convert energy to heat at 100% efficiency
- Optional safety grilles are available
- Heater has sealed wiring compartment that allows units for washdown

NOTE: *Metal Sheathed: used indoors or outdoors in high-traffic areas. Maintain at least 5 ft. in radiant path, between bottom of heater and combustible material. Pigtail element leads for a more positive connection in high-traffic areas where physical abuse.

BRM SERIES INDUSTRIAL INFRARED HEATER

MODELS & SPECIFICATIONS											
CATALOG NO.	UPC	WATTS	VOLTS	PHASE	REFLECTIVE ANGLE	ELEMENT TYPE	SHIP WT. (LBS)				
BRM2081	6 85360 14314 9	2,000	208	1	90° Symm	Metal Sheath	18				
BRM2021	6 85360 14315 6		240								
BRM2041	6 85360 14316 3		480								
BRM2061	6 85360 14317 0		600								
BRM4581	6 85360 14318 7	4,500	208	1			90° Symm	Metal Sheath	18		
BRM4521	6 85360 14319 4		240								
BRM4541	6 85360 14320 0		480								
BRM4561	6 85360 14321 7		600								
BRM6083	6 85360 14322 4	6,000	208	1 and 3					90° Symm	Metal Sheath	25
BRM6023	6 85360 14323 1		240	1							
BRM6071	6 85360 14324 8		277								
BRM6043	6 85360 14325 5		480	1 and 3							
BRM6063	6 85360 14326 2	600									
BRM13583	6 85360 14327 9	13,500	208	3	90° Symm	Metal Sheath					55
BRM13523	6 85360 14328 6		240	1							
BRM13571	6 85360 14329 3		277								
BRM13543	6 85360 14330 9		480	1 and 3							
BRM13563	6 85360 14331 6		600								

NOTE: See page 124 for infrared accessories. Ground Fault Detection: Ground fault detection equipment is designed to monitor for any gradual changes in the insulation level due to humidity or mechanical damage as it develops, thus, de-energizing the load to prevent arcing type faults, preventing premature element failure and potential fire damage. As a safety precaution it is highly recommended that industrial infrared heaters must be protected by ground fault detection. Failure to comply could result in a building fire or serious equipment damage.

