

# BASEBOARD HEATERS

## COMMERCIAL BASEBOARD HEATER | BKOC SERIES



NAVAJO WHITE



**IDEAL SPACES** | Bedrooms; Living/Family Rooms; Kitchens; Bathrooms; Basements; Offices; Conference Rooms; Hallways; Lobbies; Waiting Rooms

**COLORS** | Navajo White

**DIMENSIONS** | 6-27/32" H x 2-13/16" D (Length varies)

- Commercial-grade 20-gauge cold rolled front cover and brackets allow heater to withstand rigors of commercial applications
- Steel-sheathed heating element combines the durability of a steel tubular heater with the excellent heat transfer characteristics of aluminum fins
- Ideal for basic, zoned primary/secondary heating
- Built-in wire-way facilitates end-to-end installation of continuous-run heaters
- Large, pre-wired junction boxes at each end are provided with knockouts in the rear, bottom, inside and outside
- High temperature safety limit
- Pre-notched marks for mounting guide
- UL-listed to be surface mounted on any wall and flat on any floor type; pre-notched marks for mounting guide
- No fans; convection heat minimizes air flow, reducing flow of bacteria and dust
- Chimney-fin element designed for maximum air circulation
- Air flow directed away from walls to help prevent wall streaking

### SUGGESTED CONTROLS

view page 147 for more information

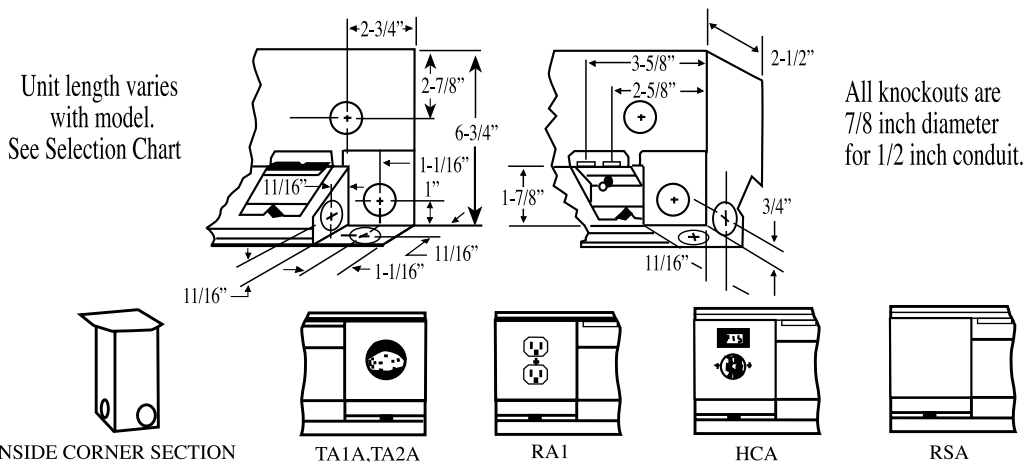

# BASEBOARD HEATERS

## MODELS & SPECIFICATIONS

CATALOG NO.	UPC	VOLTS	WATTS	AMPS	LENGTH (IN)	SHIP WT. (LBS)
BKOC25126W	6 85360 01009 0	120	500	4.2	30"	7.8
BKOC25026W	6 85360 00985 8	208	500	2.4		
BKOC25426W	6 85360 01036 6	240/208	500/376	2.1/1.8		
BKOC25726W	6 85360 01067 0	277/240/208	500/376/282	1.8/1.6/1.4		
BKOC2513W	6 85360 01013 7	120	750	6.5	36"	9.0
BKOC2503W	6 85360 00989 6	208	750	3.6		
BKOC2543W	6 85360 01040 3	240/208	750/564	3.1/2.7		
BKOC2573W	6 85360 01071 7	277/240/208	750/564/423	2.7/2.4/2.0		
BKOC2514W	6 85360 01017 5	120	1000	8.3	48"	11.5
BKOC2504W	6 85360 00993 3	208	1000	4.8		
BKOC2544W	6 85360 01044 1	240/208	1000/752	4.2/3.6		
BKOC2574W	6 85360 01075 5	277/240/208	1000/752/564	3.6/3.1/2.7		
BKOC2515W	6 85360 01021 2	120	1250	10.4	60"	13.0
BKOC2505W	6 85360 00997 1	208	1250	6.0		
BKOC2545W	6 85360 01048 9	240/208	1250/940	5.2/4.5		
BKOC2575W	6 85360 01079 3	277/240/208	1250/940/705	4.5/3.9/3.4		
BKOC2516W	6 85360 01025 0	120	1500	12.6	72"	15.5
BKOC2506W	6 85360 01001 4	208	1500	7.2		
BKOC2546W	6 85360 01052 6	240/208	1500/1128	6.3/5.4		
BKOC2576W	6 85360 01083 0	277/240/208	1500/1128/846	5.4/4.7/4.1		
BKOC2508W	6 85360 01005 2	208	2000	9.6	96"	20
BKOC2548W	6 85360 01056 4	240/208	2000/1504	8.3/7.2		
BKOC2578W	6 85360 01087 8	277/240/208	2000/1504/1128	7.2/6.3/5.4		
BKOC25008W	6 85360 00981 0	208	2500	12.0		
BKOC25408W	6 85360 01032 8	240/208	2500/1880	10.4/8.7	96"	20
BKOC25708W	6 85360 01063 2	277/240/208	2500/1880/1410	9.0/7.5/6.8		

## CONTROLS & ACCESSORIES

CATALOG NO.	UPC	DESCRIPTION	SHIP WT. (LBS)
TA1AW	0 98319 73041 1	SP Thermostat, rated 22A @ 120-277V	1
TA1TPAW	0 98319 73042 8	Tamper-Resistant Version of TA1AW	1
TA2AW	0 98319 73043 5	DP Thermostat, rated 22A @ 120-277V	1
TA2TPAW	0 98319 73044 2	Tamper-Resistant Version of TA2AW	1
HCA2415/20W	0 98319 73046 6	240V Load Transfer Switch, 20A	1
HCA1215/20W	0 98319 73045 9	120V Load Transfer Switch, 20A	1
RSA1224	0 98319 71480 0	120V/24V Transformer Relay, 22A	1
RSA2024	0 98319 71485 5	208V/24V Transformer Relay, 22A	1
RSA2424	0 98319 71490 9	240V/24V Transformer Relay, 22A	1
RSA2724	0 98319 71495 4	277V/24V Transformer Relay, 19A	1
RA1W	0 98319 73047 3	120V Duplex Receptacle	1
DSW2W	0 98319 73049 7	Double-Pole Power On/Off Switch rated 20A @ 120-277V	1
PR24	0 98319 71367 4	Single-Pole Power Relay, 24VControl rated 30A @ 120-240V, 23A @ 277V	1
PR120	0 98319 71368 1	Same as PR24 except with 120V Control	1
ICAW	0 98319 73050 3	Inside Corner	1
RA1COMPW	0 98319 73048 0	Duplex Receptacle Cover only – carton of 10	1

## FILLER SECTIONS

CATALOG NO.	UPC	DESCRIPTION	SHIP WT. (LBS.)
FS12	0 98319 73150 0	1 ft. Filler Section	2
FS24	0 98319 73151 7	2 ft. Filler Section	4
FS36	0 98319 73152 4	3 ft. Filler Section	6
FS48	0 98319 73153 1	4 ft. Filler Section	8
FSJ2	73154 8	2 in. Joiner Strip	1/2

## BLANK SECTIONS

CATALOG NO.	UPC	DESCRIPTION	SHIP WT. (LBS)
BKOCBDA2W	6 85360 00931 5	2.6 ft. Blank Section	4
BKOCBDA3W	6 85360 00933 9	3 ft. Blank Section	5
BKOCBDA4W	6 85360 00935 3	4 ft. Blank Section	7
BKOCBDA5W	6 85360 00937 7	5 ft. Blank Section	9
BKOCBDA6W	6 85360 00939 1	6 ft. Blank Section	11
BKOCBDA8W	6 85360 00941 4	8 ft. Blank Section	14

NOTE: For high-altitude baseboard heater (mounted above 7,500 ft.), add suffix "H" to catalog number. 8 ft. length baseboards must be ordered in multiples of two pieces for shipment.