



Item#: **84254**

## LED STADIUM LIGHT

**OUTDOOR POLE/ARM-MOUNTED AREA AND ROADWAY LUMINAIRES - ARCHITECTURAL FLOOD AND SPOT LUMINAIRES**

### FEATURES

- Elegant and modern appearance
- Housing coated with corrosion resistant polyester powder
- Multi-faceted optic design to distribute light evenly and reduce glare
- Advanced technology, no electrical interference.
- 240° adjustable angle
- Surge protection device

### - APPLICATION

Arenas, sports fields, plazas, airports, courtyards and public areas.

### ELECTRICAL

Wattage	750W
Voltage	277-480V
Power Factor	0.9
Total Harmonic Distortion (THD)	<15

### LIGHTING PERFORMANCE

Lumens	97500
Lumens Per Watt (Lm/W)	130
Color Temperature (CCT)	5000K
Color Rendering (CRI)	70
R9 (Red Value)	--
R13 (Skin Tones)	--
Beam Angle	30°
Light Distribution	--
BUG Rating (Backlight, Uplight, and Glare)	--
Dimmable Lighting Control	<i>Dimmable</i> 0-10V, Range 10% - 100%

### ENVIRONMENT

Operating Temperature	-22° ~ 122°F
Suitable Location	<b>WET</b>
Ingress Protection Rating	IP66

### LIFESPAN

Average Life (Hours)	50,000
Warranty (Years)	<b>5</b>

### COMPONENTS

LED Light Source	Luxeon 5050
Driver	ESD-480S10ADT (2 ea.)

### CONSTRUCTION

Housing	Forged Aluminum
Lens	PC
Base / Power Supply	Hard Wired
Finish	Black
Effective Projected Area (EPA)	2.92 ft <sup>2</sup>
Wind Shear Rating	116.3 mph

### QUALIFICATIONS

Model Number	RSTL-750-D-EV-50K
--------------	-------------------



*Published lumens on LED products are approximate and may vary slightly. • Specifications are subject to change without notice.*

PERFORMANCE DATA

Item#: **84254**  
**LED STADIUM LIGHT**



**DIMENSIONS** (Inches)

Length	20.3"
Width/Diameter	20.5"
Height	25"
Net Weight (Lbs)	50.7

**SUPPORTING DOCUMENTS** (Grey = not available at this time.)

Product Sheet	VIEW
Install Instructions	VIEW
IES Download from Web Item	VIEW
LM79	VIEW
LM80	VIEW

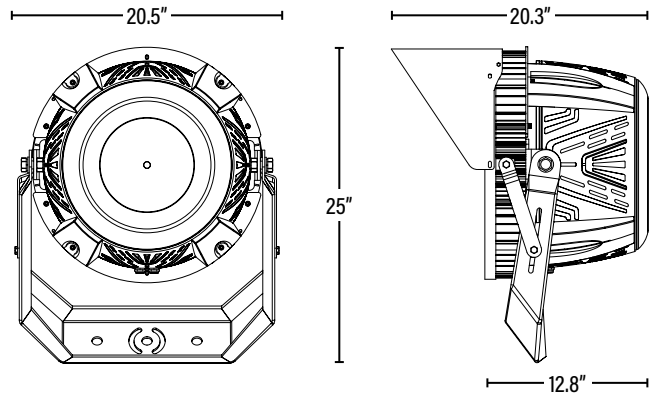

**PACKAGING**

Master Carton	1
Country of Origin	China
HS Tariff	9405.10.6020

**UPC**

--

**DIMENSIONS** (LxWxH)

24.4" x 22.4" x 16.3"

**GROSS WEIGHT** (Lbs)

60.6

**ORDERING \*** Qualification Model # RSTL-750-D-EV-50K

ITEM#	DESCRIPTION	CASE
84254	LED 750W STADIUM/50K/30°/277-480V/DIMMABLE/V2 - SUPERIOR LIFE®	1

**ACCESSORIES**

84205	LASER SCOPE KIT FOR LED STADIUM LIGHT - SUPERIOR LIFE®	12
-------	--	----

**REPLACEMENT PARTS**

ESD-480S10ADT	480W REPLACEMENT LED DRIVER	1
---------------	-----------------------------	---

**ADDITIONAL INFORMATION:**

Item may be special order; please consult with P.Q.L.

ITEM INFORMATION