



Item#: **84250**

## LED STADIUM LIGHT

**OUTDOOR POLE/ARM-MOUNTED AREA AND ROADWAY LUMINAIRES - ARCHITECTURAL FLOOD AND SPOT LUMINAIRES**

### FEATURES

- Elegant and modern appearance
- Housing coated with corrosion resistant polyester powder
- Multi-faceted optic design to distribute light evenly and reduce glare
- Advanced technology, no electrical interference.
- 240° adjustable angle
- Surge protection device

### - APPLICATION

Arenas, sports fields, plazas, airports, courtyards and public areas.

PERFORMANCE DATA

### ELECTRICAL

Wattage	497W
Voltage	277-480V
Power Factor	0.9
Total Harmonic Distortion (THD)	11.6

### LIGHTING PERFORMANCE

Lumens	77598
Lumens Per Watt (Lm/W)	156
Color Temperature (CCT)	5000K
Color Rendering (CRI)	74
R9 (Red Value)	-23
R13 (Skin Tones)	74
Beam Angle	30°
Light Distribution	Very Short, Type IV
BUG Rating (Backlight, Uplight, and Glare)	B5 - Ux - G5
Dimmable Lighting Control	<i>Dimmable</i> 0-10V, Range 10% - 100%

### ENVIRONMENT

Operating Temperature	-22° ~ 122°F
Suitable Location	<b>WET</b>
Ingress Protection Rating	IP66

### LIFESPAN

Average Life (Hours)	50,000
Warranty (Years)	<b>5</b>

### COMPONENTS

LED Light Source	Luxeon 5050
Driver	ESD-240S660DT (2 ea.)

### CONSTRUCTION

Housing	Die-Cast Aluminum
Lens	PC
Base / Power Supply	Hard Wired
Finish	Black
Effective Projected Area (EPA)	1.59 ft <sup>2</sup>
Wind Shear Rating	116.3 mph

### QUALIFICATIONS

Model Number	RSTL-500-D-EV-50K
--------------	-------------------



Visit [www.designlights.org/search](http://www.designlights.org/search) to confirm qualification. • Published lumens on LED products are approximate and may vary slightly. • Specifications are subject to change without notice.

Item#: **84250**  
**LED STADIUM LIGHT**



ITEM INFORMATION

**DIMENSIONS** (Inches)

Length	16.3"
Width/Diameter	15.9"
Height	19.7"
Net Weight (Lbs)	27.6

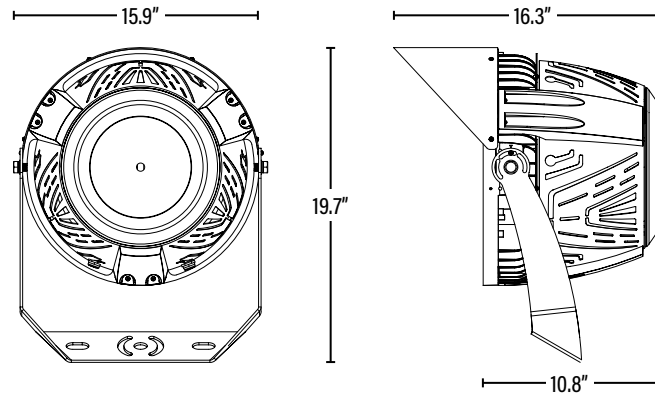

**SUPPORTING DOCUMENTS** (Grey = not available at this time.)

Product Sheet	VIEW
Install Instructions	VIEW
IES Download from Web Item	VIEW
LM79	VIEW
LM80	VIEW

**PACKAGING**

	UPC	DIMENSIONS (LxWxH)	GROSS WEIGHT (Lbs)	
Master Carton	1	--	17.7" x 17.7" x 14"	32
Country of Origin	China			
HS Tariff	9405.10.6020			

**ORDERING \*** Qualification Model # RSTL-500-D-EV-50K

ITEM#	DESCRIPTION	CASE
84250	LED 500W STADIUM/50K/30°/277-480V/DIMMABLE/V2 - SUPERIOR LIFE® DLC®	1

**ACCESSORIES**

84080	U BRACKET AND SLIP FITTER FOR 300W-600W STADIUM LIGHT - SUPERIOR LIFE®	5
84205	LASER SCOPE KIT FOR LED STADIUM LIGHT - SUPERIOR LIFE®	12

**REPLACEMENT PARTS**

ESD-240S660DT	240W REPLACEMENT LED DRIVER	1
---------------	-----------------------------	---

**ADDITIONAL INFORMATION:**

Item may be special order; please consult with P.Q.L.