



Item#: **84231** **LED STADIUM LIGHT**

OUTDOOR POLE/ARM-MOUNTED AREA AND ROADWAY LUMINAIRES - ARCHITECTURAL FLOOD AND SPOT LUMINAIRES

FEATURES

- Elegant and modern appearance
- Housing coated with corrosion resistant polyester powder
- Multi-faceted optic design to distribute light evenly and reduce glare
- Advanced technology, no electrical interference.
- 240° adjustable angle
- Surge protection device

- APPLICATION

Arenas, sports fields, plazas, airports, courtyards and public areas.

ELECTRICAL

Wattage	399W
Voltage	100-277V
Power Factor	0.9
Total Harmonic Distortion (THD)	10.5

LIGHTING PERFORMANCE

Lumens	63076
Lumens Per Watt (Lm/W)	158
Color Temperature (CCT)	5000K
Color Rendering (CRI)	74
R9 (Red Value)	-22
R13 (Skin Tones)	74
Beam Angle	30°
Light Distribution	Very Short, Type I
BUG Rating (Backlight, Uplight, and Glare)	B5 - U1 - G2
Dimmable Lighting Control	<i>Dimmable</i> 0-10V, Range 10% - 100%

ENVIRONMENT

Operating Temperature	-22° ~ 122°F
Suitable Location	WET
Ingress Protection Rating	IP66

LIFESPAN

Average Life (Hours)	50,000
Warranty (Years)	5

COMPONENTS

LED Light Source	Luxeon 5050
Driver	EUM-240S670DG (2 ea.)

CONSTRUCTION

Housing	Die-Cast Aluminum
Lens	PC
Base / Power Supply	Hard Wired
Finish	Black
Effective Projected Area (EPA)	1.59 ft ²
Wind Shear Rating	116.3 mph

QUALIFICATIONS

Model Number	RSTL-400-D-MV-50K
--------------	-------------------



Visit www.designlights.org/search to confirm qualification. • Published lumens on LED products are approximate and may vary slightly. • Specifications are subject to change without notice.

Item#: **84231**
LED STADIUM LIGHT



DIMENSIONS (Inches)

Length	16.3"
Width/Diameter	15.9"
Height	19.7"
Net Weight (Lbs)	27.6

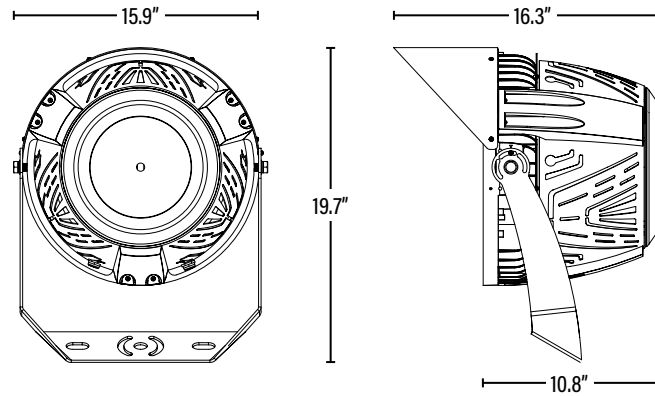

SUPPORTING DOCUMENTS (Grey = not available at this time.)

Product Sheet	VIEW
Install Instructions	VIEW
IES Download from Web Item	VIEW
LM79	VIEW
LM80	VIEW

PACKAGING

		UPC	DIMENSIONS (LxWxH)	GROSS WEIGHT (Lbs)
Master Carton	1	899645001806	17.7" x 17.7" x 14"	32
Country of Origin	China			
HS Tariff	9405.10.6020			

ORDERING * Qualification Model # RSTL-400-D-MV-50K

ITEM#	DESCRIPTION	CASE
84231	LED 400W STADIUM/50K/30°/100-277V/DIMMABLE/V2 - SUPERIOR LIFE® DLC®	1

ACCESSORIES

84080	U BRACKET AND SLIP FITTER FOR 300W-600W STADIUM LIGHT - SUPERIOR LIFE®	5
84205	LASER SCOPE KIT FOR LED STADIUM LIGHT - SUPERIOR LIFE®	12

REPLACEMENT PARTS

EUM-240S670DG	240W REPLACEMENT LED DRIVER	1
---------------	-----------------------------	---

ADDITIONAL INFORMATION:

Item may be special order; please consult with P.Q.L.

ITEM INFORMATION