



SELECTABLE  
WATTAGE & CCT

## Item#: **83101** **LED SPEC-SELECT™ CANOPY** PARKING GARAGE LUMINAIRES

### FEATURES

- Adjustable wattage and color temperature.
- One piece corrosion resistant, die-cast housing with powder coat paint finish.
- High impact UV stabilized PC lens for even light distribution.
- Compact design.
- Easy installation.
- 1/2" threaded knockouts on 3 sides.
- Surface mount with J-box or pendent mount with 3/4" conduit.

### APPLICATION

Parking structures, gas stations, garages, underpasses, covered walkways, storage areas and security lighting.

### ELECTRICAL

Wattage	40W / 50W / 60W
Voltage	120-277V
Power Factor	0.9
Total Harmonic Distortion (THD)	--

### LIGHTING PERFORMANCE

Lumens	5000-7500
Lumens Per Watt (LPW)	125
Color Temperature (CCT)	3000K / 4000K / 5000K
Color Rendering (CRI)	80
R9 (Red Value)	--
R13 (Skin Tones)	--
Beam Angle	100° x 60°
Light Distribution	--
BUG Rating (Backlight, Uplight, and Glare)	--
Dimmable Lighting Control	<i>Dimmable</i> 0-10V, Range 10% - 100%

### ENVIRONMENT

Operating Temperature	-40° ~ 104°F
Suitable Location	<b>WET</b>
Ingress Protection Rating	IP65

### LIFESPAN

Average Life (Hours)	50,000
Warranty (Years)	<b>5</b>

### COMPONENTS

LED Light Source	--
Driver	ARC-DI-60I1450

### CONSTRUCTION

Housing	Aluminum
Lens	PC / Frosted
Base / Power Supply	Hard Wired
Finish	Black

### QUALIFICATIONS

Model Number	SSC-B-FSC1-1-MV-BLK
--------------	---------------------



Published lumens on LED products are approximate and may vary slightly. • Specifications are subject to change without notice.

PERFORMANCE DATA

Item#: **83101**  
**LED SPEC-SELECT™ CANOPY**



ITEM INFORMATION

**DIMENSIONS** (Inches)

Length	10.4"
Width/Diameter	10.4"
Height	3.5"
Net Weight (Lbs)	--

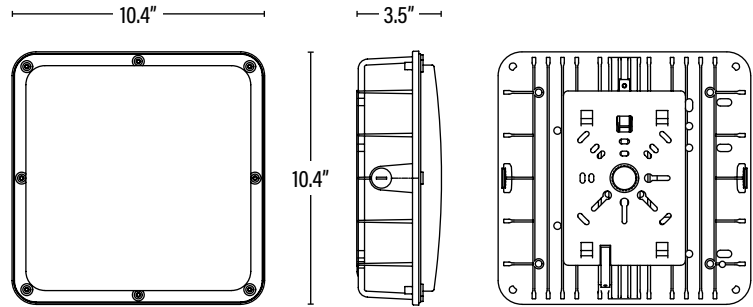

**SUPPORTING DOCUMENTS** (Grey = not available at this time.)

Product Sheet	VIEW
Install Instructions	VIEW
IES Download from Web Item	VIEW
LM79	VIEW
LM80	VIEW

**PACKAGING**

		UPC	DIMENSIONS (LxWxH)	GROSS WEIGHT (Lbs)
Master Carton	4	10811768029410	15.7" x 10.9" x 10.9"	--
Individual Box	1	811768029413	10.8" x 10.8" x 3.7"	--
Country of Origin	China			
HS Tariff	9405.10.6020			

**ORDERING** Qualification Model # SSC-B-FSC1-I-MV-BLK

ITEM#	DESCRIPTION	CASE
83101	LED SPEC-SELECT™ CANOPY 40W/50W/60W - 30K/40K/50K/120-277V/BLACK/DIMMABLE - SUPERIOR LIFE®	4

**ACCESSORIES**

54888	360° BI-LEVEL AND DAYLIGHT HARVESTING MICROWAVE SENSOR 26' DIA, 8-40' HEIGHT 800W/1200W • 120/277V - SL®	100
-------	--	-----

**REPLACEMENT PARTS**

ARC-DI-6011450	60W REPLACEMENT DRIVER	1
----------------	------------------------	---

**ADDITIONAL INFORMATION:**

**Note:** To prevent water damage which may shorten the life of an exterior mounted fixture; the fixture should be properly weather sealed according to the installation instructions or between the fixture base and mounting surface. Damage due to improper installation may void the warranty.