



SELECTABLE
WATTAGE & CCT

Item#: 83099

LED SPEC-SELECT™ CANOPY

PARKING GARAGE LUMINAIRES

FEATURES

- Adjustable wattage and color temperature.
- One piece corrosion resistant, die-cast housing with powder coat paint finish.
- High impact UV stabilized PC lens for even light distribution.
- Compact design.
- Easy installation.
- 1/2" threaded knockouts on 3 sides.
- Surface mount with J-box or pendent mount with 3/4" conduit.

APPLICATION

Parking structures, gas stations, garages, underpasses, covered walkways, storage areas and security lighting.

ELECTRICAL

Wattage	21W / 30W / 40W
Voltage	120-277V
Power Factor	0.9
Total Harmonic Distortion (THD)	--

LIGHTING PERFORMANCE

Lumens	2625-5000
Lumens Per Watt (LPW)	125
Color Temperature (CCT)	3000K / 4000K / 5000K
Color Rendering (CRI)	80
R9 (Red Value)	--
R13 (Skin Tones)	--
Beam Angle	100° x 60°
Light Distribution	--
BUG Rating (Backlight, Uplight, and Glare)	--
Dimmable Lighting Control	<i>Dimmable</i> 0-10V, Range 10% - 100%

ENVIRONMENT

Operating Temperature	-40° ~ 104°F
Suitable Location	WET
Ingress Protection Rating	IP65

LIFESPAN

Average Life (Hours)	50,000
Warranty (Years)	5

COMPONENTS

LED Light Source	--
Driver	ARC-DI-40I1000

CONSTRUCTION

Housing	Aluminum
Lens	PC / Frosted
Base / Power Supply	Hard Wired
Finish	White

QUALIFICATIONS

Model Number	SSC-A-FSC1-1-MV-WHT
--------------	---------------------



Published lumens on LED products are approximate and may vary slightly. • Specifications are subject to change without notice.

PERFORMANCE DATA

Item#: **83099**
LED SPEC-SELECT™ CANOPY



ITEM INFORMATION

DIMENSIONS (Inches)

Length	10.4"
Width/Diameter	10.4"
Height	3.5"
Net Weight (Lbs)	--

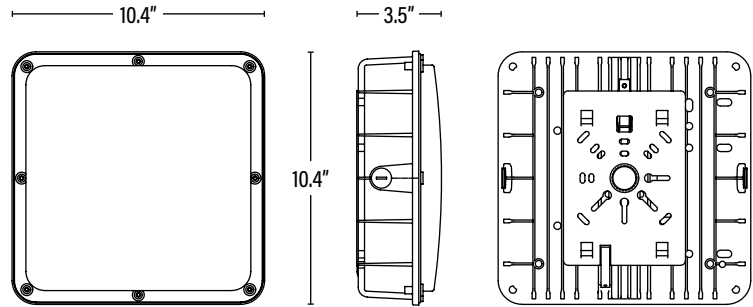

SUPPORTING DOCUMENTS (Grey = not available at this time.)

Product Sheet	VIEW
Install Instructions	VIEW
IES Download from Web Item	VIEW
LM79	VIEW
LM80	VIEW

PACKAGING

		UPC	DIMENSIONS (LxWxH)	GROSS WEIGHT (Lbs)
Master Carton	4	10811768026099	15.7" x 10.9" x 10.9"	--
Individual Box	1	811768026092	10.8" x 10.8" x 3.7"	--
Country of Origin	China			
HS Tariff	9405.10.6020			

ORDERING Qualification Model # SSC-A-FSC1-1-MV-WHT

ITEM#	DESCRIPTION	CASE
83099	LED SPEC-SELECT™ CANOPY 21W/30W/40W - 30K/40K/50K/120-277V/WHITE/DIMMABLE - SUPERIOR LIFE®	4

ACCESSORIES

54888	360° BI-LEVEL AND DAYLIGHT HARVESTING MICROWAVE SENSOR 26' DIA, 8-40' HEIGHT 800W/1200W • 120/277V - SL®	100
-------	--	-----

REPLACEMENT PARTS

ARC-DI-40I1000	40W REPLACEMENT DRIVER	1
----------------	------------------------	---

ADDITIONAL INFORMATION:

Note: To prevent water damage which may shorten the life of an exterior mounted fixture; the fixture should be properly weather sealed according to the installation instructions or between the fixture base and mounting surface. Damage due to improper installation may void the warranty.