

82233 • FLUORESCENT EMERGENCY BACKUP

INSTALL INSTRUCTIONS



PLEASE FIND A QUALIFIED ELECTRICIAN FOR INSTALLATION. Please read the instructions before you install and use the luminaire.

IMPORTANT SAFEGUARDS

1. READ AND FOLLOW ALL SAFETY INSTRUCTIONS.
2. To prevent high voltage from being present on the output leads (red and yellow), do not join battery connector until installation is completed and AC power is supplied to the emergency ballast.
3. All electrical connections must be in accordance with local code and the National Electric Code.
4. To reduce the risk of electric shock, disconnect both normal and emergency power supplies and battery connector of the emergency ballast before installation.
5. Do not use outdoors. This emergency ballast is for indoor fixtures except air outlets or hazardous location fixtures.
6. An unswitched AC power source is required (120 or 277 Volts). Properly cap the unused AC lead.
7. Do not mount near gas or electric heaters.

8. Do not attempt to service the battery. A sealed, no-maintenance battery is used that is not field replaceable. Replace the entire battery when necessary.
9. This emergency ballast is for one 2' through 8' or two 2' through 4' instant start, rapid start, U shape or circline, T8 through T12 fluorescent lamps including energy saving and long 4 Pin compacts for 90 minutes at reduced light output.
10. This product should be mounted in location and at heights where it will not readily be subject to tampering by unauthorized personnel.
11. This emergency ballast is for factory or field installation.
12. Do not use this emergency ballast other than intended use.
13. All servicing should be performed by qualified personnel only.

SAVE THESE INSTRUCTIONS



Contains Nickel-Cadmium Rechargeable Battery. Must be recycled or disposed properly.

CAUTION: To prevent electrical shock, disconnect the AC power by turning off the circuit breaker and battery connector must be open. Join battery connector after installation and after AC power is turned on.

INSTALLING THE EMERGENCY BALLAST

1. Install the emergency ballast in the AC ballast channel or enclosed wireway so the wire leads are not exposed at least 1/2" away from the AC ballast(s). Refer to (Fig. 1) for typical mounting.
2. Make all electrical connections in accordance with local code and National Electrical Code.
3. The test switch with LED charge indicator may be installed on the fixture in the ceiling or remote distance (up to 50 feet).
4. The emergency ballast may be remotely installed up to 1/2 (half) of the distance from ballast to lamp specified by the AC ballast manufacturer. For example, if AC ballast manufacturer recommends up to 25 feet, then the emergency ballast should not exceed 12 1/2 feet. Under no circumstances, the emergency ballast can be remotely mounted up to 50 feet from fixture.

Fig. 1

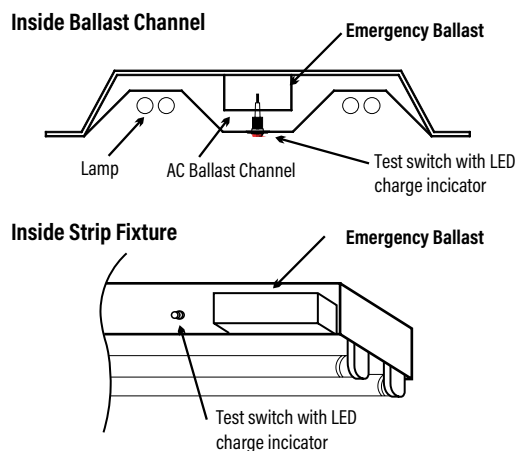
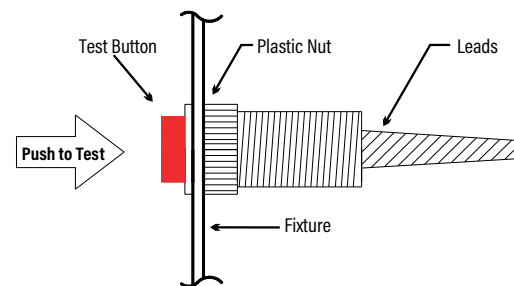

Fig. 2

Installing the Test Switch with LED Charge Indicator



Drill a 5/8" hole and install Test Switch on the appropriate location on the fixture

WIRING THE EMERGENCY BALLAST

1. Emergency ballast can be used with one or two lamp fixture and operates one or two lamps in the emergency mode. Please see next page "Table 1" showing type of lamps and number of lamps at emergency mode. Then select "Wiring Diagram Number" for wiring.
2. Refer to the Wiring Diagrams on page 2 & 3 for the proper wiring.
3. Emergency ballast and AC ballast must be on the same branch circuit.
4. Emergency ballast requires an unswitched AC power source (120 or 277 VAC).
5. When emergency ballast is used with switched fixture, an additional unswitched hot (120 or 277 VAC) wire must be run to junction box and connected to the emergency ballast. (Refer to Fig.3 on the next page).
6. After installation is completed, supply AC power to emergency ballast and join the battery connector.

82233 • FLUORESCENT EMERGENCY BACKUP

INSTALL INSTRUCTIONS



TABLE 1: GUIDE FOR WIRING DIAGRAMS

Emergency ballast can be used with most 2'-8' lamps. Refer to the below chart for the type of lamp(s) operated and the number of lamps to be operated in emergency mode.

OPTION	TYPE OF LAMP	EMERGENCY OPERATION	VIOLET LEADS (SEE NOTE)	WIRING DIAGRAMS
1	2'-4' T8~T12 Single, Bi Pin	One lamp	Connected	1, 2, 3, 4, 5, 6, 7, 8
2	5'-8' T8~T12 Single, Bi Pin	One lamp	Disconnected	1, 2, 3, 4, 8
3	2'-4' T8~T12 Single, Bi Pin	Two lamp	Disconnected	9, 10

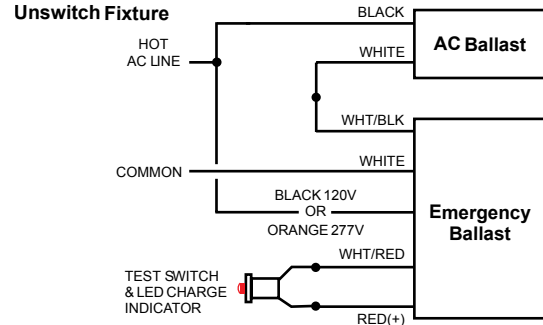
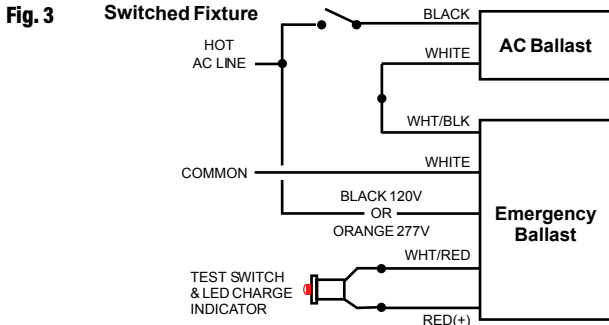

NOTE: The 6" violet leads provides for selection of lamp as shown in the above. The emergency ballast shipped from the factory with the violet leads disconnected and capped. Connect the violet leads when needed.

MOUNTING THE TEST SWITCH AND CHARGE INDICATOR LIGHT

Select appropriate location on the side of the fixture so that Test Switch can be seen after installation. Allow for proper clearance and drill or punch 5/8" hole. Remove the plastic nut and push the Test Switch into the 5/8" hole. Secure the Test Switch with plastic nut. (Refer to Fig. 2 on first page) Connect the wires as indicated in wiring diagrams below and on Page 3.

LABELS

Attach the appropriate label to the Test Switch Plate and attach Re-lamping Label for lamp type and wattage to fixture. The Caution and Re-lamping label must be on the fixture in a readily visible location to anyone attempting to service the fixture.

COMPLETE INSTALLATION

When the Installation is complete, supply AC power to emergency ballast and join the battery connector.

OPERATION

This emergency ballast is primarily designed to be used with compact fluorescent lamp down lighting fixtures. When AC power is applied, the charging indicator light is illuminated, indicating battery is being charged. When power fails, the emergency ballast automatically switches to emergency power (internal battery), operating one or two lamps at reduced illumination.

MAINTENANCE

This emergency ballast has integrated test switch and charge indicator. Press test switch to test emergency operation. Allow minimum 24 hours battery charging before conducting a one hour test. Recommended periodical test schedule is as follows:

1. Visually inspect the charging indicator light monthly. It should be illuminated.
2. Test the emergency operation of fixture for 30 seconds at 30 day intervals. One or two lamps should be operated at reduced illumination.
3. Conduct 90 min. battery discharge test once a year. One or two lamps should be operated at reduced illumination.

EMERGENCY BALLAST AND AC BALLAST MUST BE FED FROM THE SAME BRANCH CIRCUIT

TYPICAL SCHEMATICS ONLY. MAY BE USED WITH THEIR BALLASTS. CONSULT THE FACTORY FOR OTHER WIRING DIAGRAMS.

WIRING DIAGRAMS for 1-LAMP or 2-LAMP Emergency Operation

ONE (1) LAMP INSTANT START BALLAST

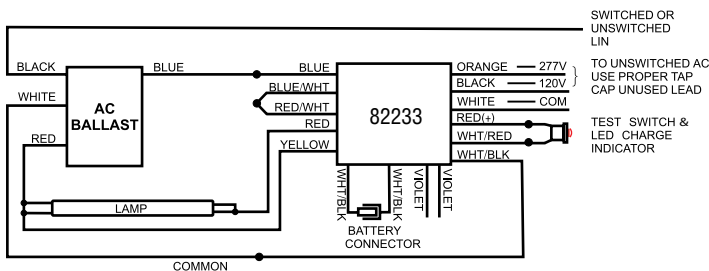

ONE (1) LAMP RAPID START BALLAST

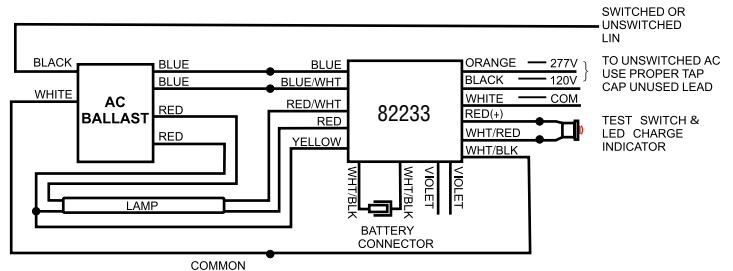

82233 • FLUORESCENT EMERGENCY BACKUP

INSTALL INSTRUCTIONS



EMERGENCY BALLAST AND AC BALLAST MUST BE FED FROM THE SAME BRANCH CIRCUIT
 TYPICAL SCHEMATICS ONLY. MAY BE USED WITH THEIR BALLASTS. CONSULT THE FACTORY FOR OTHER WIRING DIAGRAMS.

WIRING DIAGRAMS for 1-LAMP or 2-LAMP Emergency Operation

TWO (2) LAMP INSTANT START BALLAST

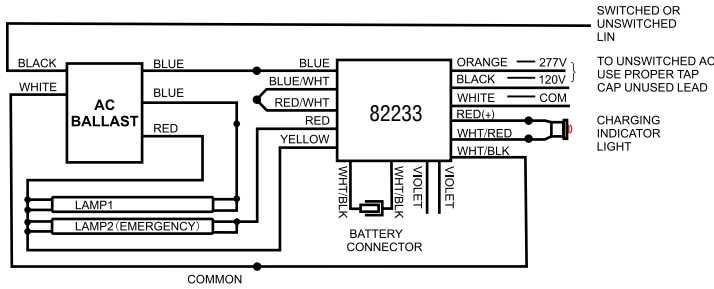

TWO (2) LAMP RAPID START BALLAST

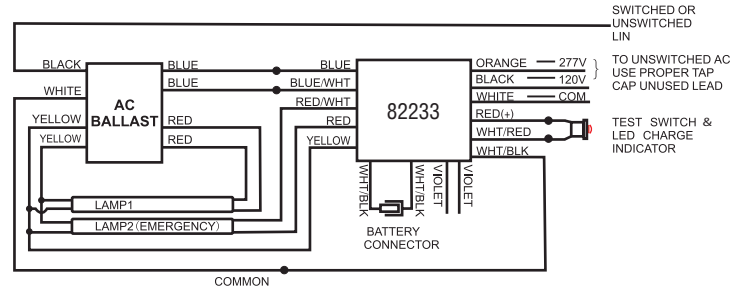

THREE (3) LAMP INSTANT START BALLAST

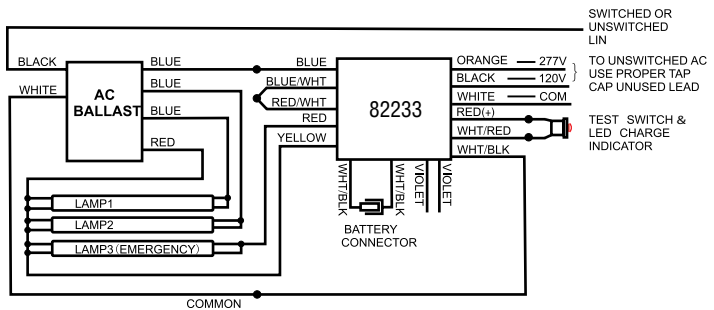

THREE (3) LAMP RAPID START BALLAST

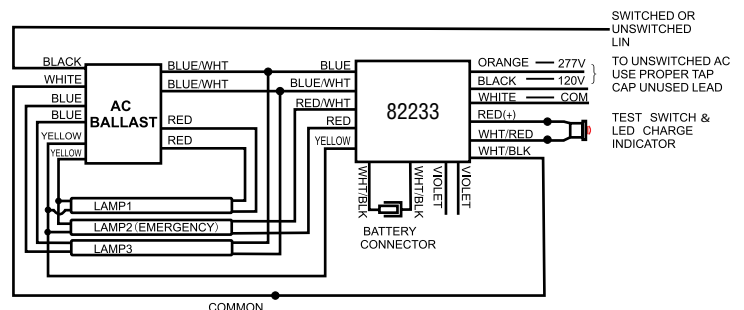

FOUR (4) LAMP INSTANT START BALLAST

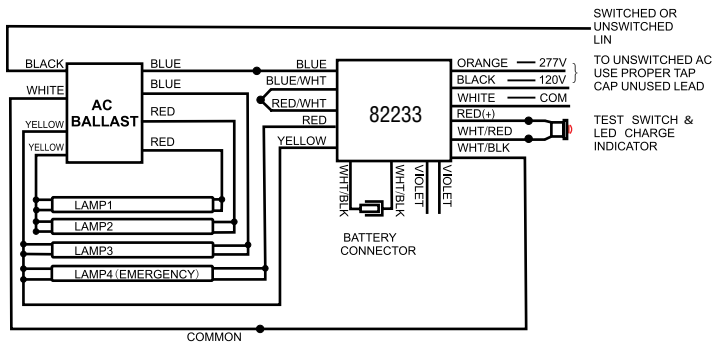

TWO (2) LAMP INSTANT START BALLAST

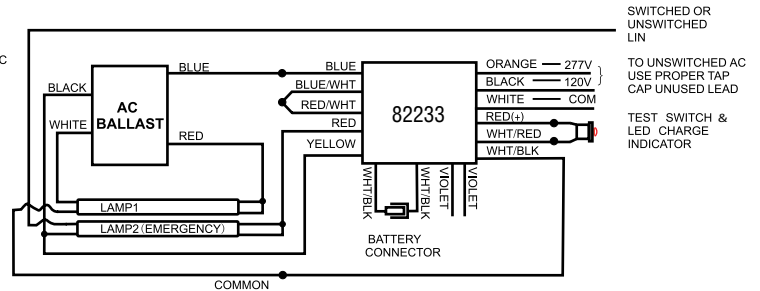

TWO (2) LAMP INSTANT BALLAST W/2 LAMP EMERGENCY OPERATION

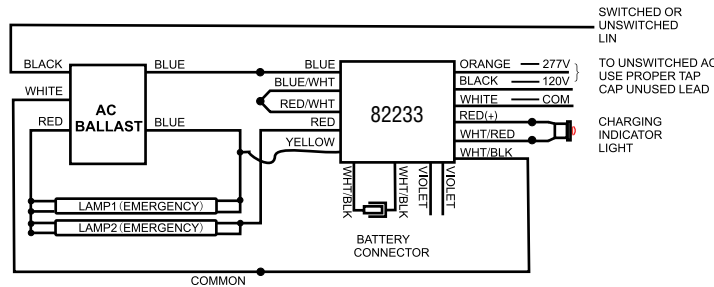

TWO (2) LAMP RAPID START BALLAST W/2 LAMP EMERGENCY OPERATION

