

LED SPEC-SELECT™ DESIGNER STRIP RETROFIT

INSTALL INSTRUCTIONS



PLEASE FIND A QUALIFIED ELECTRICIAN FOR INSTALLATION. Please read the instructions before you install and use the luminaire.

WARNING, CAUTIONS AND OPERATING INSTRUCTIONS

WARNING – Risk of fire or electric shock. LED Retrofit Kit installation requires knowledge of luminaires electrical systems. If not qualified, do not attempt installation. Contact a qualified electrician.

WARNING – Risk of fire or electric shock. Install this kit only in the luminaires that have the construction features and dimensions shown in the photographs and/or drawings and where the input rating of the retrofit kit does not exceed the input rating of the luminaire.

WARNING – To prevent wiring damage or abrasion, do not expose wiring to edges of sheet metal or other sharp objects.

WARNING – Risk of fire or electric shock. Luminaire wiring and electrical parts may be damaged when drilling for installation of LED retrofit kit. Check for enclosed wiring and components.

Only those open holes indicated in the photographs and/or drawings may be made or altered as a result of kit installation. Do not leave any other open holes in an enclosure of wiring or electrical components.

WARNING: RISK OF FIRE OR ELECTRICAL SHOCK

- Turn off electrical power at fuse or circuit breaker box before wiring fixture to the power supply.
- Turn off the power when you perform any maintenance.
- Verify that supply voltage is correct by comparing it with the luminaire label information.
- All wiring connections should be capped with UL approved wire connectors.

CAUTION: RISK OF INJURY

- Avoid looking directly at the light source for prolonged periods of time while it is on.
- Account for small parts and destroy packing material, as these may be hazardous to children.
- Risk of burn. Disconnect power and allow fixture to cool before changing bulb or handing fixture.
- Green ground screw provided in proper location. DO NOT RELOCATE.
- Minimum 90° supply conductors.
- Suitable for Dry or Damp locations.

KIT INCLUDES		
Part	Quantity	
	4FT	8FT
Retrofit Housing	1	2
Installation Bracket	2	3
Lens	1	2
Installation Instructions	1	1
Label	1	1

! WARNING - TURN OFF POWER SUPPLY FROM MAIN CIRCUIT BREAKER BEFORE INSTALLING OR SERVICING.

THE KITS HAVE BEEN TESTED, FULLY AND PROPERLY MOUNTED IN A FIXTURE AS SIMILAR AS POSSIBLE TO THE KIT'S INTENDED USE. THE UNIVERSAL DESIGN FITS MOST 4.25" TO 5.25" WIDE T8/T12 FLUORESCENT STRIPS.

INSTALLATION STEPS:

1. Shut off power to existing fixture. Disconnect the black and the white power supply wire (and ground wire if equipped) to existing ballast.
2. Remove the original lamps from the existing fixture. *(Recycle lamps according to state specific recycling guidelines.)*
3. Remove ballast cover, ballast, socket-bars and wiring. (Fig. 1)

Continued on next page...

Fig. 1

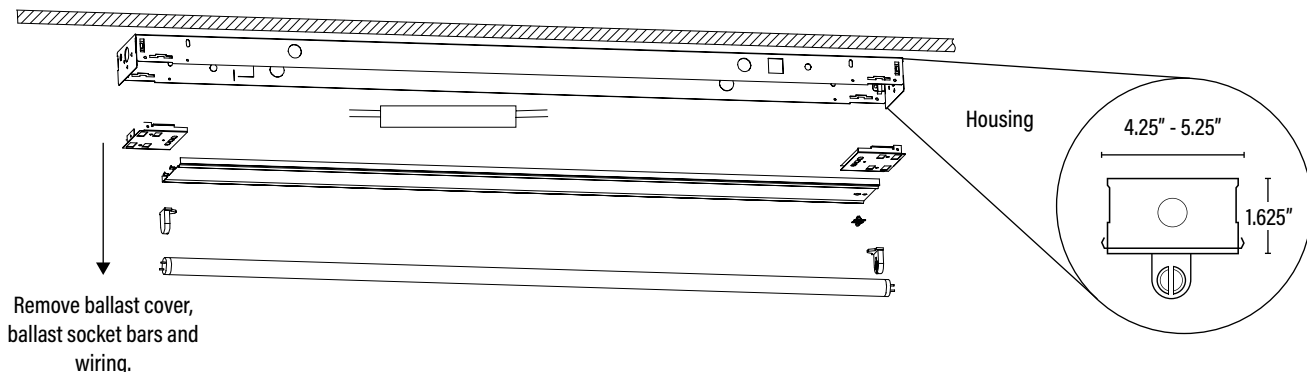

LED SPEC-SELECT™ DESIGNER STRIP RETROFIT

INSTALL INSTRUCTIONS



WARNING - TURN OFF POWER SUPPLY FROM MAIN CIRCUIT BREAKER BEFORE INSTALLING OR SERVICING.

INSTALLATION STEPS (cont'd):

4. Install retrofit brackets using screws. (Fig. 2)
5. Make electrical connections per wiring diagram.
6. Install LED Retrofit Assembly.
7. Install lens - After installation check to make sure the lens is completely secure, snapped inside the entire length of the lamp body and fitted under the end cap. Gently pull down on the lens to ensure it does not shift.
8. Restore power to fixture. (Fig. 3)

GENERAL WIRING DIAGRAM

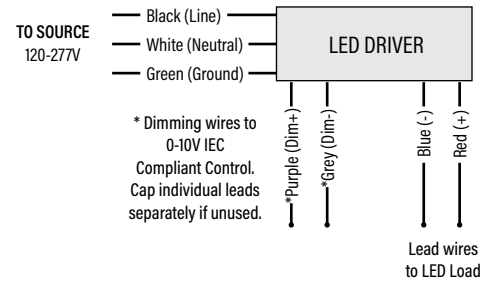

Fig. 2

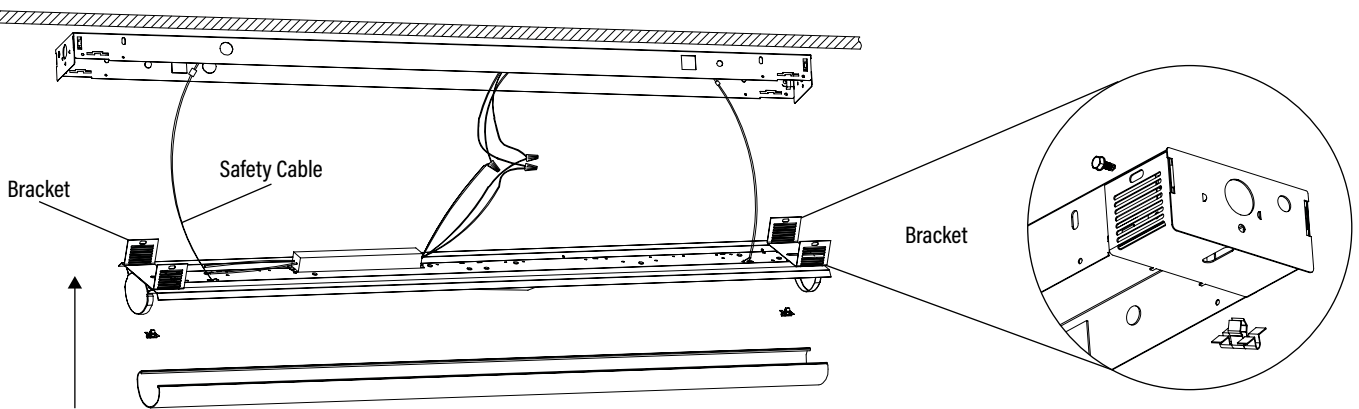
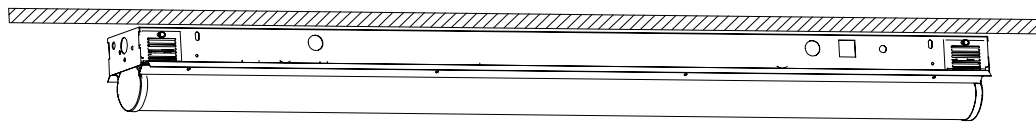

Fig. 3



FIELD ADJUSTABLE WATTAGE & CCT (Fig. 4)

The end user may adjust the color temperature and lumen output, respectively, by the two slide switches integrated into the side of the fixture. Each switch has 3 options (left, middle and right), each position corresponds to 1 of 3 color temperatures (Warm White, Cool White, and Sky-Brite®) and 1 of 3 wattages, which can be adjusted to the desired combination.

Default Settings for 55594: 40W, 5000K

Default Settings for 55597: 75W, 5000K

1. Switches are located on the LED Module driver box.
2. Select a wattage and color temperature by sliding switch left or right respectively to the desired value.

Fig. 4

