



Item#: **55582-8WEM**
LED 2X4 SPEC-SELECT™
BACK-LIT PANEL

2X4 LUMINAIRES FOR AMBIENT LIGHTING OF INTERIOR COMMERCIAL SPACES

FEATURES

Spec-Select™ Panels feature adjustable wattage and color temperature for the perfect balance of light in any application.

- Energy efficient
- No flickering
- 8W emergency battery pre-installed

APPLICATION

Ideal for retrofitting inefficient fixtures in malls, hospitals, airports, offices, lobbies and other residential and commercial applications.

PERFORMANCE DATA

ELECTRICAL

Wattage	30W / 40W / 50W
Voltage	120-277V
Current	0.42-0.18A
Power Factor	0.9
Total Harmonic Distortion (THD)	10

LIGHTING PERFORMANCE

Lumens	3630-5550
Lumens Per Watt (Lm/W)	111
Color Temperature (CCT)	3500K / 4100K / 5000K
Color Rendering (CRI)	82
R9 (Red Value)	2
R13 (Skin Tones)	81
Beam Angle	120°
Light Distribution	Type VS
BUG Rating (Backlight, Uplight, and Glare)	B2 - U0 - G1
Dimmable Lighting Control	<i>Dimmable</i> 0-10V, Range 10% - 100%

ENVIRONMENT

Operating Temperature	-4 ~ 113°F
Suitable Location	DAMP
Ingress Protection Rating	IP40

LIFESPAN

Average Life (Hours)	50,000
Warranty (Years)	5

COMPONENTS

LED Light Source	Runlite 2835
Driver	XZ-SE50B-380125
Emergency Battery	55394

CONSTRUCTION

Housing	Aluminum
Lens	Frosted
Base / Power Supply	Hard Wired
Finish	White

QUALIFICATIONS



Visit www.designlights.org/search to confirm qualification. • Published lumens on LED products are approximate and may vary slightly. • Specifications are subject to change without notice.

Item#: **55582-8WEM**
LED 2X4 SPEC-SELECT™ BACK-LIT PANEL



DIMENSIONS (Inches)

Length	47.8"
Width	23.7"
Height	1.6"
Weight (Lbs)	9.2

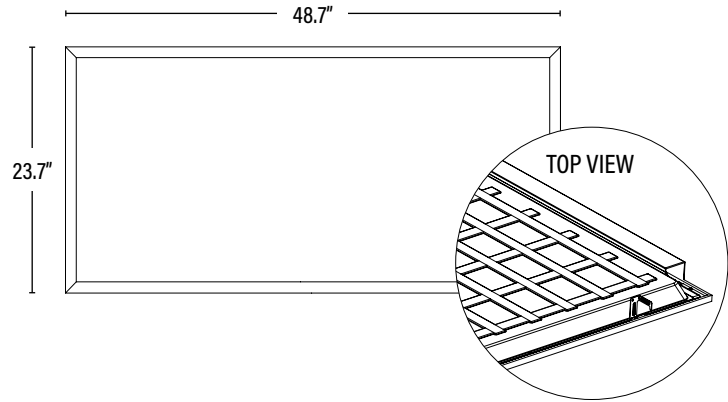

SUPPORTING DOCUMENTS (Grey = not available at this time.)

Product Sheet	VIEW
Install Instructions	VIEW
Emergency Battery	VIEW
IES Download from Web Item	VIEW
LM79	VIEW
LM80	VIEW

PACKAGING

		UPC	DIMENSIONS (LxWxH)	GROSS WEIGHT (Lbs)
Master Carton	2	10811768025764	50" x 8.8" x 25.8"	21.5
Individual Box	1	811768025767	N/A	10.8
Country of Origin	China			
HS Tariff	9405.10.6020			

ORDERING

ITEM#	DESCRIPTION	CASE
55582-8WEM	LED 2X4 SPEC-SELECT™ PANEL - 30/40/50W/35-50K/120-277V/DIMMABLE/8W EM BATTERY - SUPERIOR LIFE® DLC®	2

ACCESSORIES

55129	2X4 FLANGE KIT FOR PANEL & TROFFER/WHITE - SUPERIOR LIFE®	1
55532	2X4 SURFACE MOUNTED KIT FOR LED BACK-LIT PANEL/WHITE - SUPERIOR LIFE®	1
55445	SUSPENDED CABLE MOUNTING KIT FOR LED PANEL/V6 - SUPERIOR LIFE®	100

REPLACEMENT PARTS

55394	EMERGENCY PACK FOR LED PANEL 8W/90 MIN - SUPERIOR LIFE®	1
XZ-SE50B-380125	REPLACEMENT LED DRIVER	1

ADDITIONAL INFORMATION:

- Default settings; 50W, 5000K.
- When the fixture is in emergency mode the color temperature will default to 5000K.
- The color temperature and wattage may be adjusted by two slide switches integrated into the driver. The color temperature and wattage should be selected prior to installation.

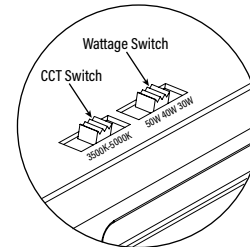

ITEM INFORMATION