



Item#: **55580-8WEM**

**LED 1X4 SPEC-SELECT™**

**BACK-LIT PANEL**

**1X4 LUMINARIES FOR AMBIENT LIGHTING OF INTERIOR COMMERCIAL SPACES**

### FEATURES

Spec-Select™ Panels feature adjustable wattage and color temperature for the perfect balance of light in any application.

- Energy efficient
- No flickering
- 8W emergency battery pre-installed

### APPLICATION

Ideal for retrofitting inefficient fixtures in malls, hospitals, airports, offices, lobbies and other residential and commercial applications.

### ELECTRICAL

|                                 |                 |
|---------------------------------|-----------------|
| Wattage                         | 25W / 30W / 40W |
| Voltage                         | 120-277V        |
| Current                         | 0.33-0.14A      |
| Power Factor                    | 0.9             |
| Total Harmonic Distortion (THD) | 10              |

### LIGHTING PERFORMANCE

|  |  |
|--|--|
| Lumens                                     | 2900-4400                                  |
| Lumens Per Watt (Lm/W)                     | 110  |
| Color Temperature (CCT)                    | 3500K / 4100K / 5000K                      |
| Color Rendering (CRI)                      | 82   |
| R9 (Red Value)                             | 2  |
| R13 (Skin Tones)                           | 81   |
| Beam Angle                                 | 120°                                       |
| Light Distribution                         | Type VS                                    |
| BUG Rating (Backlight, Uplight, and Glare) | B2 - U0 - G1                               |
| Dimmable Lighting Control                  | <i>Dimmable</i><br>0-10V, Range 10% - 100% |

### ENVIRONMENT

|                           |             |
|---------------------------|-------------|
| Operating Temperature     | -4 ~ 113°F  |
| Suitable Location         | <b>DAMP</b> |
| Ingress Protection Rating | IP40        |

### LIFESPAN

|                      |          |
|----------------------|----------|
| Average Life (Hours) | 50,000   |
| Warranty (Years)     | <b>5</b> |

### COMPONENTS

|                   |                 |
|-------------------|-----------------|
| LED Light Source  | Runlite 2835    |
| Driver            | XZ-SE40B-380105 |
| Emergency Battery | 55394           |

### CONSTRUCTION

|                     |            |
|---------------------|------------|
| Housing             | Aluminum   |
| Lens                | Frosted    |
| Base / Power Supply | Hard Wired |
| Finish              | White      |

### QUALIFICATIONS



Visit [www.designlights.org/search](http://www.designlights.org/search) to confirm qualification. • Published lumens on LED products are approximate and may vary slightly. • Specifications are subject to change without notice.

PERFORMANCE DATA

Item#: **55580-8WEM**  
**LED 1X4 SPEC-SELECT™ BACK-LIT PANEL**



ITEM INFORMATION

**DIMENSIONS** (Inches)

|              |       |
|--------------|-------|
| Length       | 47.8" |
| Width        | 11.9" |
| Height       | 1.6"  |
| Weight (Lbs) | --    |

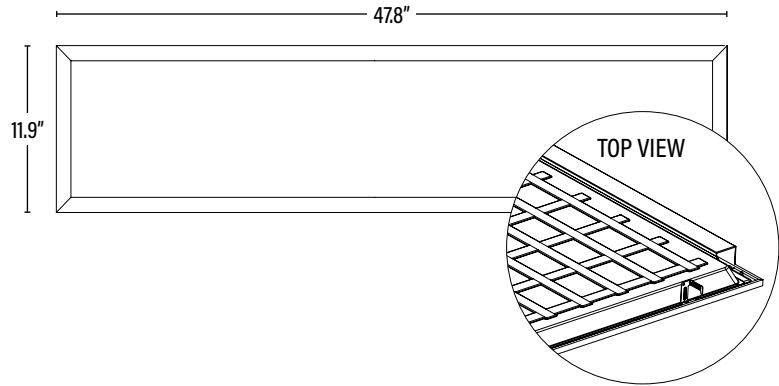

**SUPPORTING DOCUMENTS** (Grey = not available at this time.)

|                            |      |
|----------------------------|------|
| Product Sheet              | VIEW |
| Install Instructions       | VIEW |
| Emergency Battery          | VIEW |
| IES Download from Web Item | VIEW |
| LM79                       | VIEW |
| LM80                       | VIEW |

**PACKAGING**

|                   |              | UPC            | DIMENSIONS (LxWxH) | GROSS WEIGHT (Lbs) |
|-------------------|--------------|----------------|--------------------|--------------------|
| Master Carton     | 2            | 10811768024828 | --                 | --                 |
| Individual Box    | 1            | 811768024821   | N/A                | --                 |
| Country of Origin | China        |                |                    |                    |
| HS Tariff         | 9405.10.6020 |                |                    |                    |

**ORDERING**

| ITEM#      | DESCRIPTION   | CASE |
|------------|---|------|
| 55580-8WEM | LED 1X4 SPEC-SELECT™ PANEL - 25/30/40W/35-50K/120-277V/DIMMABLE/8W EM BATTERY - SUPERIOR LIFE® DLC® | 2    |

**ACCESSORIES**

|       |   |     |
|-------|---|-----|
| 55127 | 1X4 FLANGE KIT FOR PANEL & TROFFER/WHITE - SUPERIOR LIFE®             | 1   |
| 55530 | 1X4 SURFACE MOUNTED KIT FOR LED BACK-LIT PANEL/WHITE - SUPERIOR LIFE® | 1   |
| 55445 | SUSPENDED CABLE MOUNTING KIT FOR LED PANEL/V6 - SUPERIOR LIFE®        | 100 |

**REPLACEMENT PARTS**

|                 |   |   |
|-----------------|---|---|
| 55394           | EMERGENCY PACK FOR LED PANEL 8W/90 MIN - SUPERIOR LIFE® | 1 |
| XZ-SE40B-380105 | REPLACEMENT LED DRIVER                                  | 1 |

**ADDITIONAL INFORMATION:**

- Default settings; 40W, 5000K.
- When the fixture is in emergency mode the color temperature will default to 5000K.
- The color temperature and wattage may be adjusted by two slide switches integrated into the driver. The color temperature and wattage should be selected prior to installation.

