



Item#: **55525**  
**LED 2X2 NANOTECH PUREAIRE™**  
**TROFFER**  
 2X2 LUMINARIES FOR AMBIENT LIGHTING OF  
 INTERIOR COMMERCIAL SPACES

**FEATURES**

- LED light with Nanotech Air Purification technology.
- Special TTA nanocomposite coating inside the fixture inhibits bacterial and viral reproduction.
- Reduces floating airborne particles and allergens, and improves air quality.
- Powerful silent internal fan draws air across coatings.
- Tone-Select™ - remote provides selectable color temperature (CCT), dimming and On/Off function for fan and light.

**Tested and verified to be effective against:**

- Anti-Viral - H1N1, Enterovirus, Respiratory mixed viruses
- Anti-Bacterial - Superbug, Tubercle, Pseudomonas Aeruginosa, Staphylococcus, Colibacillosis, White Candida, Pneumophilia and Salmonella
- Air Pollutants - 5 Common Microbes, Formaldehyde, TVOC

**APPLICATION**

Ideal for schools, hospitals, offices, retail, commercial buildings and work areas.

**ELECTRICAL**

Wattage	50W (35W LED / 15W FAN)
Voltage	120-277V
Current	0.45A
Power Factor	≥0.95
Total Harmonic Distortion (THD)	<20

**LIGHTING PERFORMANCE**

Lumens	4000
Lumens Per Watt (Lm/W)	114
Color Temperature (CCT)	3000K / 4000K / 5000K
Color Rendering (CRI)	82
Beam Angle	120°
Light Distribution	Type VS
BUG Rating (Backlight, Uplight, and Glare)	B2 - U2 - G1
Dimmable Lighting Control	<i>Dimmable</i> using remote control.

**ENVIRONMENT**

Operating Temperature	-4° ~ 122°F
Suitable Location	<b>DAMP</b>
Ingress Protection Rating	IP54

**LIFESPAN**

Average Life (Hours)	50,000
Average Filter Life (Hours)	2160
Warranty (Years)	<b>5</b>

**COMPONENTS**

LED Light Source	LumiLED
Driver	SLE40-I1000

**CONSTRUCTION**

Housing	ABS / PC
Lens	Diffusing Lens
Base / Power Supply	Hard Wired
Finish	White Nanometer Coating
Effective Application Area	75 ft²
Clean Air Delivery Rate (CADR)	48 CFM
Noise	<40dB

**QUALIFICATIONS**

Model Number	NTPL2250SMVXXKD1
--------------	------------------



*Published lumens on LED products are approximate and may vary slightly. - Specifications are subject to change without notice.*

PERFORMANCE DATA

Item#: **55525**  
**LED 2X2 NANOTECH PUREAIRE™ TROFFER**



**DIMENSIONS** (Inches)

Length	23.6"
Width	23.6"
Height	4.8"
Net Weight (Lbs)	16.8

**SUPPORTING DOCUMENTS** (Grey = not available at this time.)

Product Sheet	VIEW
Install Instructions	VIEW
IES Download from Web Item	VIEW
LM79	VIEW
LM80	VIEW

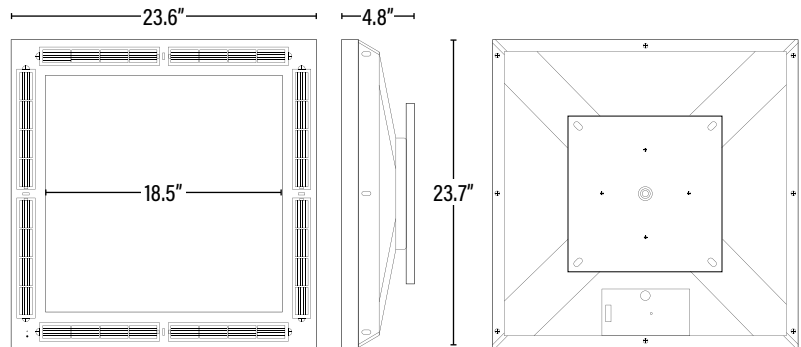

ITEM INFORMATION

**PACKAGING**

		UPC	DIMENSIONS (LxWxH)	GROSS WEIGHT (Lbs)
Master Carton	1	811768025439	--	--
Country of Origin	China			
HS Tariff	--			

**ORDERING**

ITEM#	DESCRIPTION	CASE
55525	LED 2X2 NANOTECH PUREAIRE™ TROFFER - 50W/30/40/50K/120-277V/DIMMABLE - SUPERIOR LIFE®	1

**REPLACEMENT PARTS**

55523	NANOTECH PUREAIRE™ TROFFER FILTER REPLACEMENT (4PK) - SUPERIOR LIFE®	1
55524	NANOTECH PUREAIRE™ REMOTE - SUPERIOR LIFE®	1
SLE40-I1000	40W REPLACEMENT DRIVER	1

**ADDITIONAL INFORMATION:**

- Indicator light will flicker when filters need to be replaced.