

PNL FLAT PANEL 3CCT

PROJECT: _____

SCHEDULE: _____ DATE: _____

PREPARE BY: _____

NOTES: _____

DESCRIPTION

naturaLED® features qualified DLC Back-Lit Flat Panels (PNL), an integrated LED technology with a low profile design and CCT selectable (3500K, 4000K, 5000K) and comes with additional 12V output for your control and accessories needs. This lightweight LED provides a smooth and uniform light distribution from edge-to-edge for an even and consistent color design. Perfect solution for your interior lighting needs for offices, schools, and meeting rooms. The Back-Lit Flat Panels are easily installed with maximum energy savings; comes in standard configurations of 2'x2', and 2'x4' for mounting in T-Bar/Grid ceilings or optional surface mount box kit.



Rated Life Hours 50,000
Warranty 5 Years

APPLICATIONS

Conference room, meeting rooms, offices, schools, hospitals

FEATURES

- DLC Standard
- Damp Location
- ETL Listed
- Selectable Color Temp 3CCT (3500K, 4000K, 5000K)
- Voltage: 120-277V
- Power Factor: >0.9
- Surge Protection: 2.5KV
- Beam Angle: 115°
- Dimmable: 0-10V
- CRI: 80
- Operating temperature: - 4°F - 104°F
- Lighter weight housing for easy installation
- Uniform and consistent color from edge to edge
- 5Year Warranty
- Optional for Purchase: Ceiling Mount Box, Flange Mount Kit, Emergency Driver

ACCESSORIES

- Ceiling Mount Box
- Flange Mount Kit
- Emergency LED Driver + Bracket
- Earthquake Hook (Pre-installed)

CCT SELECTABLE
Select Color Temperature by the color switch

SAMPLE NUMBER **FXPNL23/2X2/8CCT3**

FAMILY	SERIES	WATTAGE	SIZE	CRI	COLOR TEMP
FX Fixture	PNL Flat Panel Light	23 23 Watt	2X2 2ft x 2ft	8 CRI 80	CCT3 Selectable 3500K, 4000K, 5000K



BACK-LIT FLAT PANEL CCT3

CEILING & AREA LUMINAIRES

ORDERING

*P= Premium DLC / *S = Standard DLC

Watts (W)	Ordering Code	Description	CCT (K)	Lumens (Lm)	Size	Equiv. Wattage (W)	Beam Angle	Voltage	DLC (S/P)
23	7526	FXPNL38SW/2X2/8CCT3	3CCT (35/40/50K)	2,714	2'x2'	90-100	115°	120-277	S
29				3,555					
38				4,180					
28	7527	FXPNL46SW/2X4/8CCT3	3CCT (35/40/50K)	3,483	2'x4'	120-130	115°	120-277	S
39				4,750					
46				5,280					
23	9665	FXPNL23/2X2/8CCT3	3CCT (35/40/50K)	2,714	2'x2'	90-100	115°	120-277	S
29	9666	FXPNL29/2X2/8CCT3	3CCT (35/40/50K)	3,555	2'x2'	90-100	115°	120-277	S
28	9667	FXPNL28/2X4/8CCT3	3CCT (35/40/50K)	3,483	2'x4'	120-130	115°	120-277	S
39	9668	FXPNL39/2X4/8CCT3	3CCT (35/40/50K)	4,750	2'x4'	120-130	115°	120-277	S

ACCESSORIES (Ordered Separately)

Ceiling Mount Kit (4.5" Height)



P10334 MT-1X4BOX-4.5in
(1'x4' Panel Surface Mount Kit)



P10335 MT-2X2BOX-4.5in
(2'x2' Panel Surface Mount Kit)



P10336 MT-2X4BOX-4.5in
(2'x4' Panel Surface Mount Kit)

Flange Mount Kit



P10314 MT-1X4FMBOX
(1'x4' Flange Mount Kit)



P10228 MT-2X2FMBOX
(2'x2' Flange Mount Kit)



P10229 MT-2x4FMBOX
(2'x4' Flange Mount Kit)

Ceiling Mount Kit (3.0" Height)



P10416 MT-1X4BOX-3.0in
(1'x4' Panel Surface Mount Kit-3.0"height)



P10417 MT-2X2BOX-3.0in
(2'x2' Panel Surface Mount Kit-3.0"height)



P10418 MT-2X4BOX-3.0in
(2'x4' Panel Surface Mount Kit-3.0"height)

LED Panel Emergency Driver (Back-Lit) 120-277V



K7338333 FXPNL-BAEM-MT1FT-BLP/347
(Emergency backup driver mount KIT for 1'x4')



7338 BAEM8L-60BC/347-A
(Emergency backup driver for 2'x2' & 2'x4')

Micro Inverter 120-347V



7337 BAEM25-170BC/347-C
(25W Micro Inverter 120-347 w/12" Conduit)
[Field Installation](#)

DIMENSIONS

2'x 2'

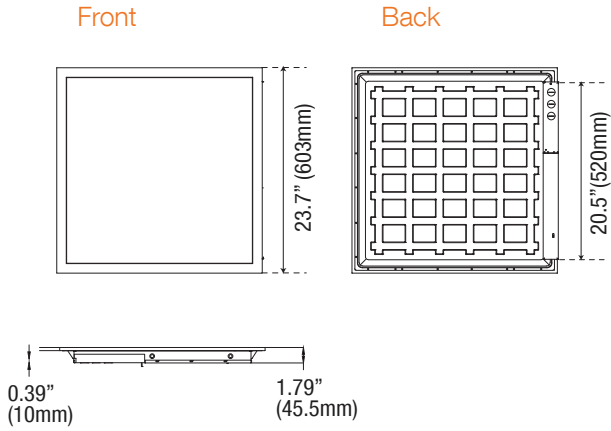

1'x 4'

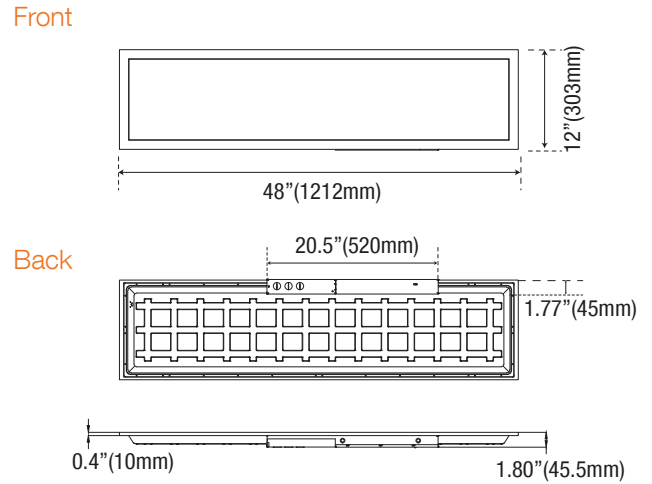

2'x 4'

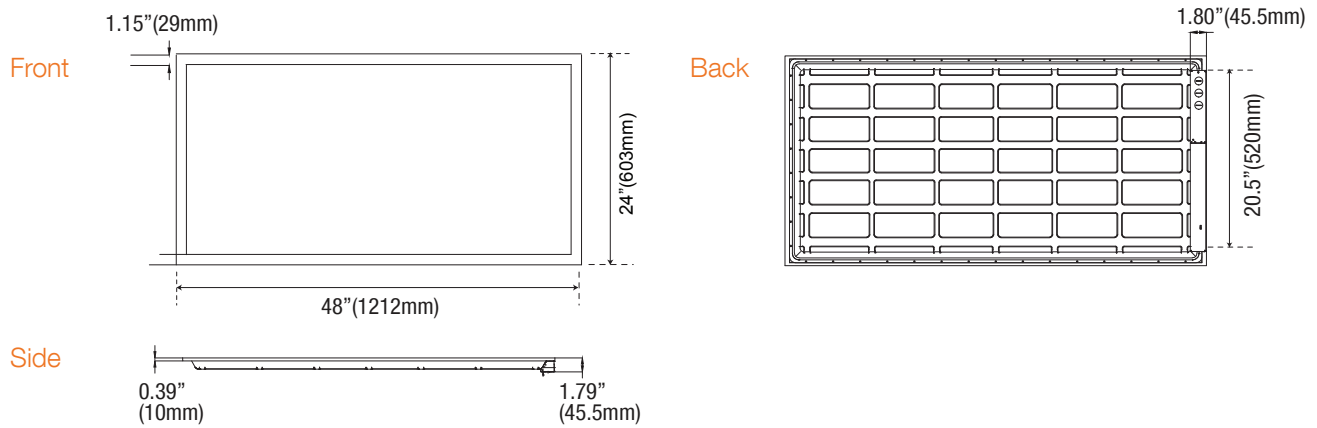

BACK-LIT FLAT PANEL CCT3

CEILING & AREA LUMINAIRES

CEILING MOUNT KIT (4.5-inch)

2'x 2'

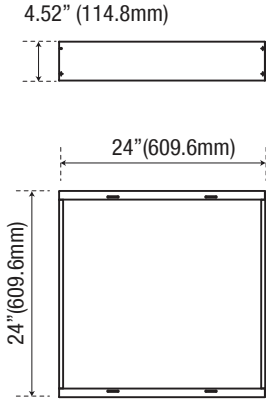

1'x 4'

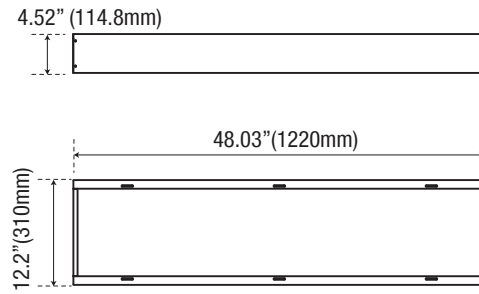

2'x 4'

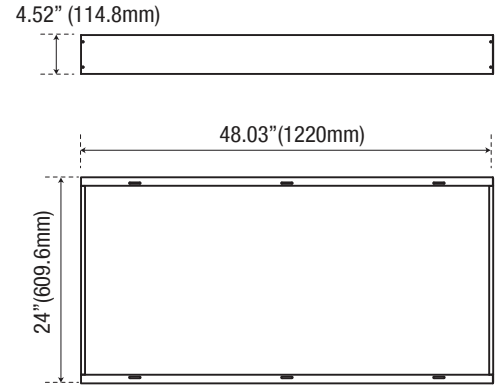

CEILING MOUNT KIT (3.0-inch)

2'x 2'

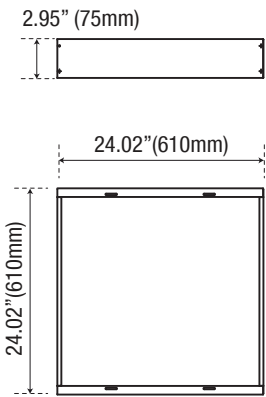

1'x 4'

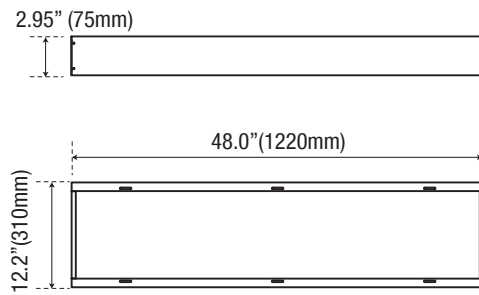

2'x 4'

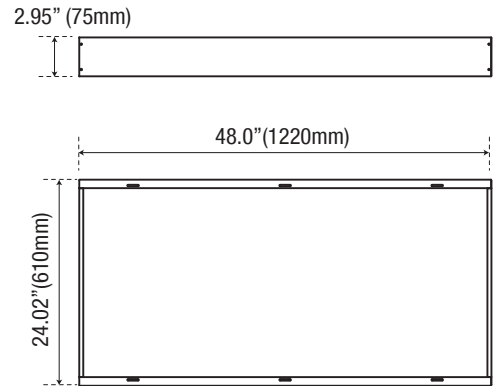

PHOTOMETRICS CHART

40 Watt - 1'x4'
DLC Standard

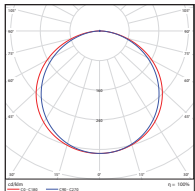

Center beam ft.	Beam Width	
1.0 ft	5.0 ft	5.0 ft
3.0 ft	14.1 ft	10.4 ft
5.0 ft	61.9 ft	15.3 ft
6.7 ft	84.2 ft	21.0 ft
6.7 ft	22.3 ft	26.1 ft
10.0 ft	15.3 ft	31.4 ft

Vert. Spread: 115.0°
HORIZ. Spread: 117.6°

40 Watt - 2'x2'
DLC Standard

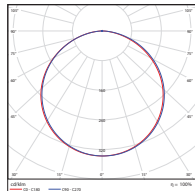

Center beam ft.	Beam Width	
1.0 ft	5.4 ft	5.4 ft
3.0 ft	14.7 ft	10.4 ft
5.0 ft	64.2 ft	15.0 ft
6.7 ft	85.0 ft	21.1 ft
6.7 ft	23.3 ft	26.2 ft
10.0 ft	16.0 ft	31.5 ft

Vert. Spread: 115.2°
HORIZ. Spread: 115.0°

50 Watt - 2'x4'
DLC Standard

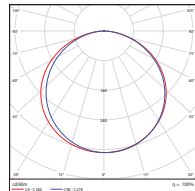

Center beam ft.	Beam Width	
1.0 ft	5.4 ft	5.6 ft
3.0 ft	18.2 ft	10.5 ft
5.0 ft	79.5 ft	15.0 ft
6.7 ft	44.3 ft	21.3 ft
6.7 ft	28.0 ft	25.4 ft
10.0 ft	19.9 ft	31.0 ft

Vert. Spread: 115.0°
HORIZ. Spread: 117.4°

PACKAGE

Case Qty 2 pcs

