

Please read this manual carefully before installation and keep it for future reference.

Installation Manual



MRCOOL®

Cool Blade ~ Because We Blow More™
Industrial HVLS Fan

Please keep this manual where the operator can easily find it. Inside, you will find helpful hints on how to use and maintain your unit properly.

For more info visit www.mrcool.com

Contents

!	Safety Precautions	2
1	Product Summary	3
2	Installation Preparation	4
3	Installation - Transition Fittings	6
4	Installation - Motor	7
5	Installation - Fan Blades	8
6	Installation - Arc Plates	9
7	Installation - Lock Wire Rope	10
8	Installation - Sling Wire Rope	11
9	Installation - Control Box	12
10	Control Box Summary	13
11	Fault Codes	14

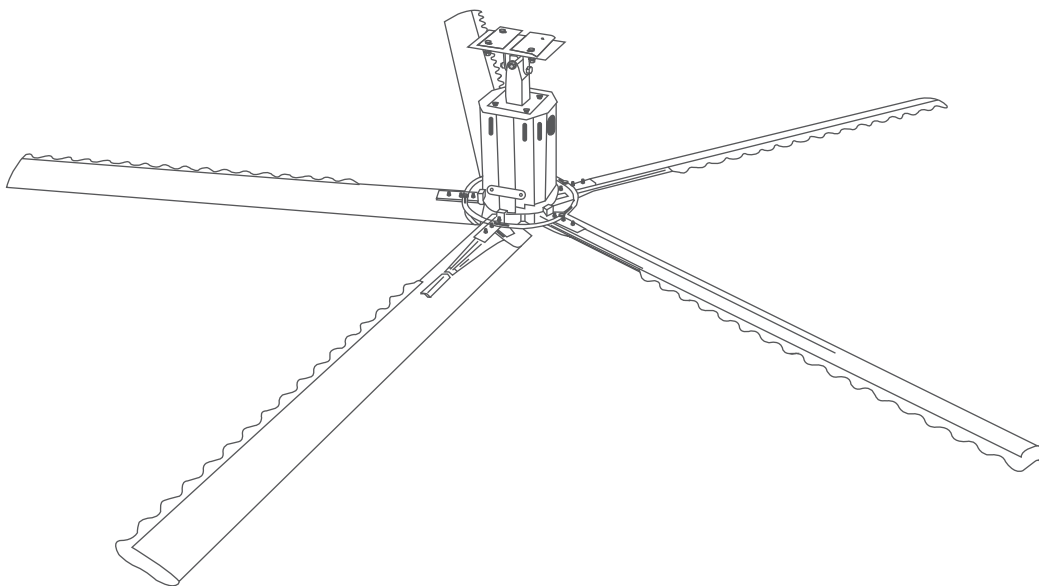

Safety Precautions



Read Before Using

Incorrect usage may cause serious damage or injury.

The seriousness of potential damage or injuries is classified as either a **WARNING** or **CAUTION**.



WARNING

This symbol indicates that ignoring instructions may cause death or serious injury.



CAUTION

This symbol indicates that ignoring instructions may cause moderate injury to your person, damage to your unit, or other property.



This symbol indicates that you should ***NEVER*** perform the indicated action.



WARNING

- Read and follow these detailed rules carefully before installing or using this product. Failure to do so can bring serious harm to yourself and others.
- Dedicated personnel must be assigned the responsibility for starting and stopping the fan and performing scheduled maintenance.
- Before starting the fan, make sure that there are no persons or obstacles within the operating range of the fan that could affect the operation of the product.
- After the power is turned off, the operator must wait for the fan blades to completely stop before leaving.
- Repair or automation adjustments can only be performed by a qualified installation engineer.
- During maintenance work, surround the area with a safety barrier that is 20 feet (6m) radius from the fan center.
- Before performing maintenance, be sure to lock the fan controller and disconnect the power supply.
- Maintenance personnel is responsible for taking corresponding protective measures according to local laws and regulations; necessary risk assessment should be performed and appropriate safety gear worn.



DO NOT perform any maintenance work when the fan is running or powered on.



DO NOT perform any maintenance work on the controller when it is powered on, except for reprogramming or viewing error codes.



DO NOT store flammable or explosive materials in the vicinity of the fan controller to avoid danger.



DO NOT keep the control device within children's reach to avoid accidental operation.



CAUTION

- MRCOOL will not be responsible for any damage caused by incorrect use or when using not as specified.
- MRCOOL will not be responsible for the safety or operation of the automatic systems if alternate parts or configurations are used.
- The installation engineer shall explain to the end user correct operating procedures and important matters needing attention before use.

INSTALLATION FLOW CHART

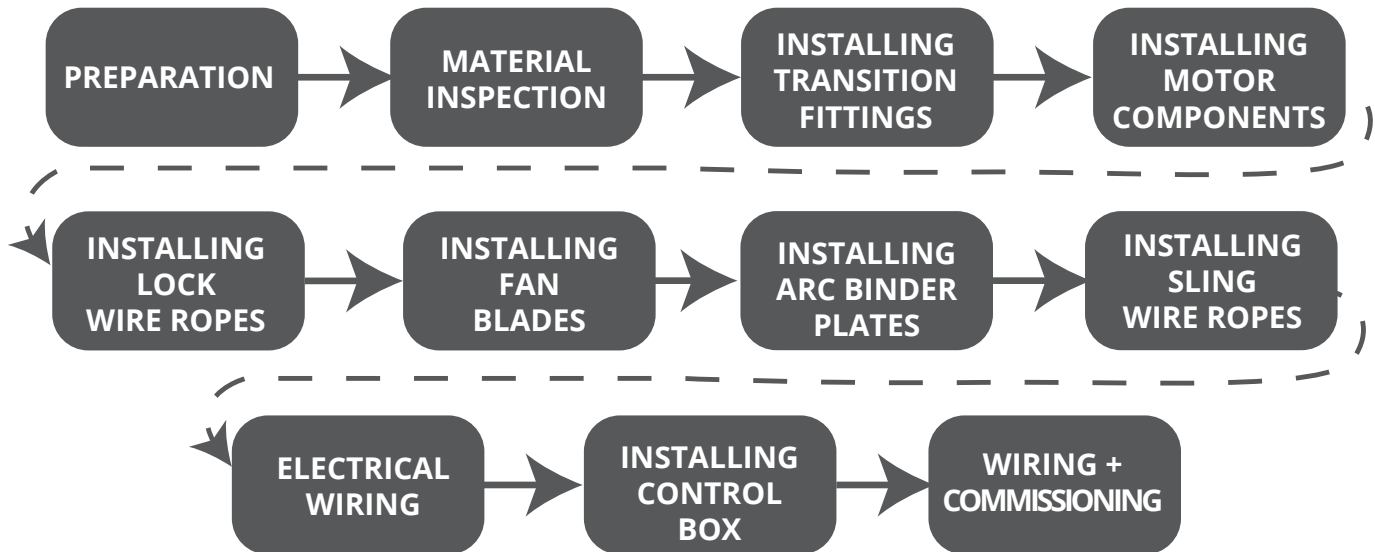

PRODUCT FEATURES

- The unique blade design creates greater air volume than many other industrial fans with similar blade diameter
- Quiet and efficient
- Minimal maintenance required
- Inexpensive operation
- Consumes less power than the average hair dryer
- Reduces “recovery time” when there is constant air flow throughout a space
- Provides a constant, even temperature throughout the space eliminating cold or hot spots (From floor to ceiling and wall to wall)
- Minimizes the need for expensive duct work in new construction for both heating and cooling systems
- Increases productivity and decreases absenteeism by providing a comfortable workplace environment

NOTE





Illustrations in this manual are for explanatory purposes only and are not drawn to scale.

Assessment Of Installation Site

Prior to the installation of industrial fans, the project personnel must assess and communicate any civil construction or installation conditions, ground facilities, locations of on-site power supplies, on-site voltage, wiring distances, and the installation locations of control boxes and fans with installation engineers.

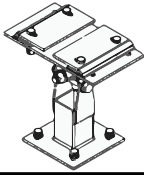
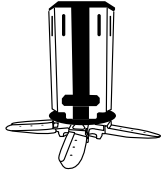
Parts Inspection

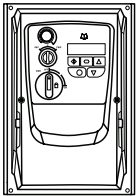
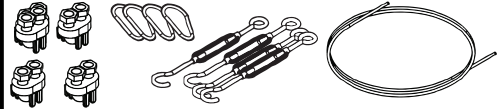
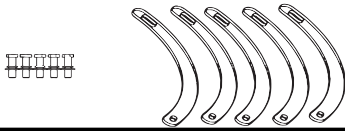
In order to ensure that the installation process goes smoothly, it is necessary for the project team to make an inventory of provided materials in combination with a list of required tools (not included), while checking the quantity and quality of each one.

Part Name	Quantity	Looks Like	Quality Requirement	<input checked="" type="checkbox"/>
Transition Fittings	1		No bad spray-coating, paint chips, severe scratches, etc.	<input type="checkbox"/>
Motor Components	1		No loosened fasteners	<input type="checkbox"/>
Fan Blade Components	5		No bad aluminum alloys, damaged plastic parts	<input type="checkbox"/>
Control Box	1		No shipping damage present	<input type="checkbox"/>
Locks & Tiger Claw Package	1 Set			<input type="checkbox"/>
Arc Compression Package	1 Set			<input type="checkbox"/>
Installing Plate Package	1 Set			<input type="checkbox"/>
Set of Screws	1 Set			<input type="checkbox"/>

Preparation Of Tools And Equipment

Specific tools and equipment are required to safely complete installation.

Standard Tools

- Pistol drill
- Saw
- Screwdrivers
- Allen wrenches
- Other wrenches
- Sockets

Standard Equipment

- Scaffolds
- Forklift
- Crane
- Ladder Truck
- Other tools not listed
- Safety Belt

NOTE

Tools will need to be selected according to site requirements. Some sites may require the use of tools and/or equipment not listed here.

Other Preparations

The project leader and installation engineer must assess staffing needs, work schedules, and the estimated installation time in addition to the quantity and site of installations when preparing for installation.

CAUTION

The following pages in this manual illustrate the HVLS installation procedures. These steps must be followed in sequential order to ensure safe and effective fan operation. A qualified engineer must use the proper tools and equipment necessary to perform the fan installation.

STEP 1

After confirming the installation location and ensuring all parts, tools, and equipment are received, the next step is installing the transition fittings. The process could be different according to your building structure.

I-Beam Installation

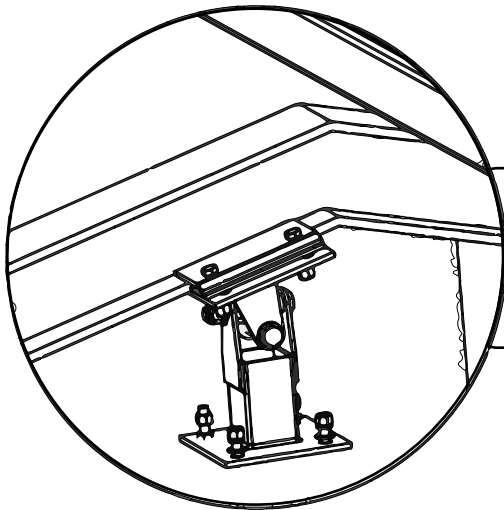
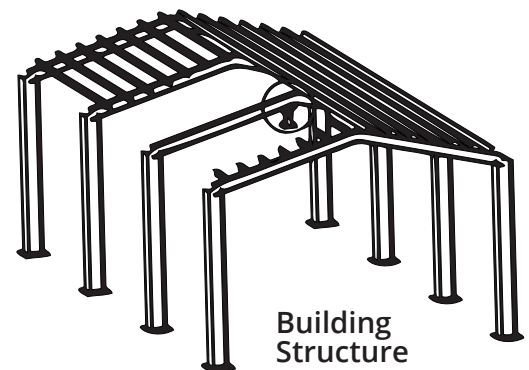
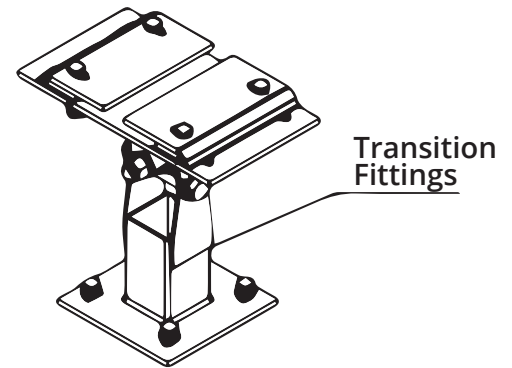
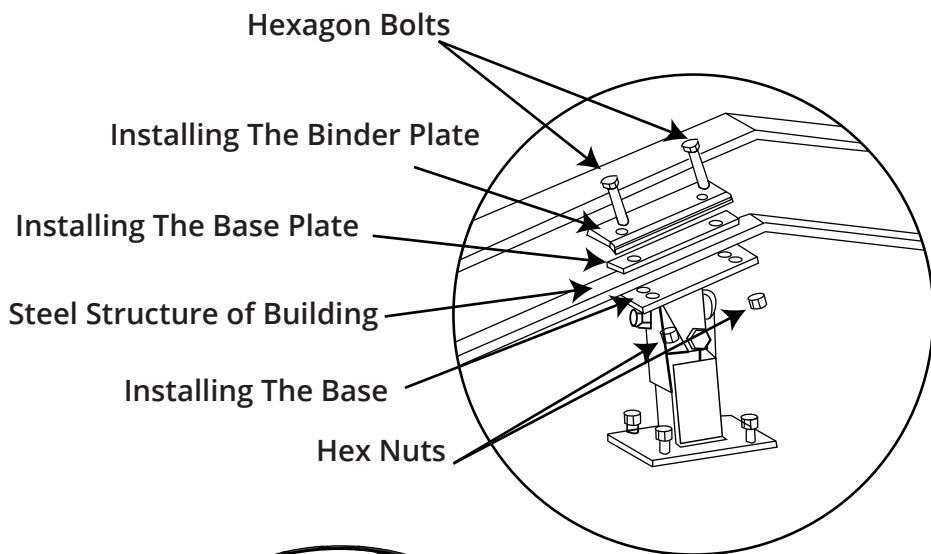

According to the diagram, install the transition fitting on the steel I-beam, and then lock the fastening screws to complete the installation.

NOTE

- Illustrations are for explanatory purposes only and are not drawn to scale.
- If you are installing the fan to a building structure other than I-Beam, you may need to purchase an additional installation bracket. Examples requiring a separate installation kit include: Z-Purlins, Solid Beam, and Angled I-Beam.
- Extensions brackets are available to drop the fan height lower. They are available in 20 inches (500mm), 32 inches (800mm), and 48 inches (1200mm) sizes.

STEP 2

After installing the transition fittings to the building structure, the next step is to install the motor component. See the following diagram that shows how to attach the motor component using hex nuts and hexagon screws.

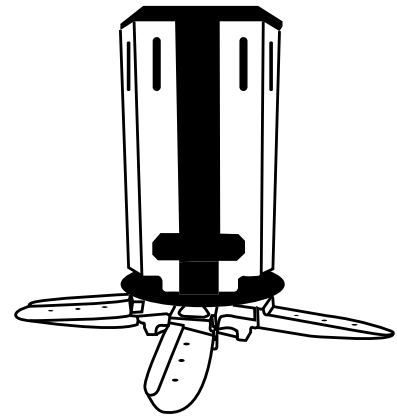

Motor Components

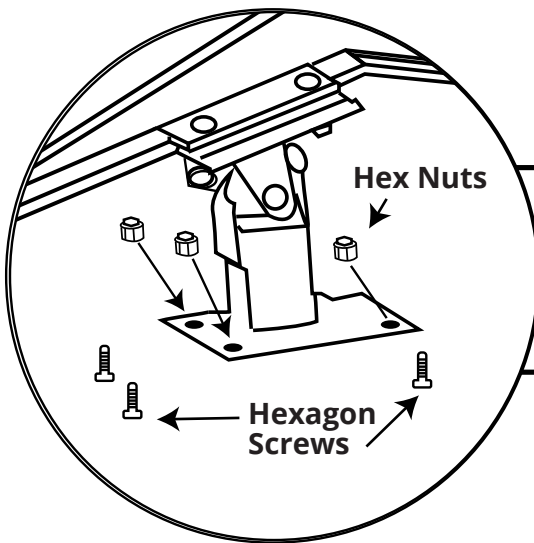

After installing the transition fitting, attach the motor component to the bottom plate using hex nuts and hexagon screws. Tighten the screws to complete installation.

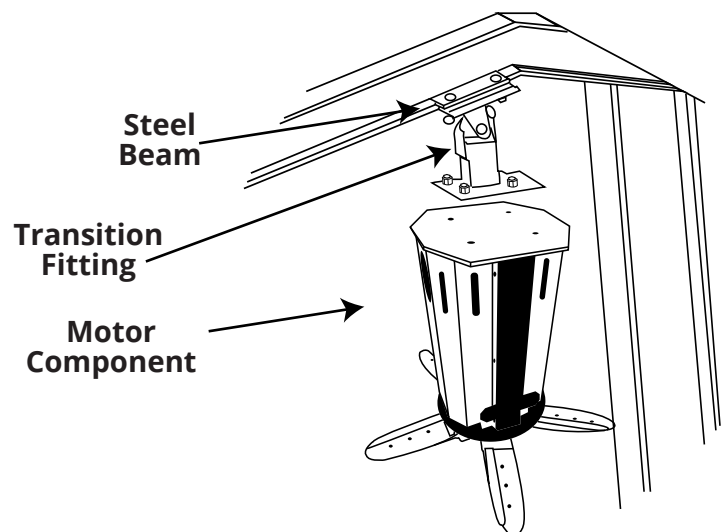

STEP 3

After installing the transition fittings and motor components, the next step is to install the fan blades. Our HVLS Industrial fan includes aluminum safety plates that connect the blades to the fan chassis forming a safe, stable, and secure design. See the following diagram that illustrates proper fan blade alignment and installation.

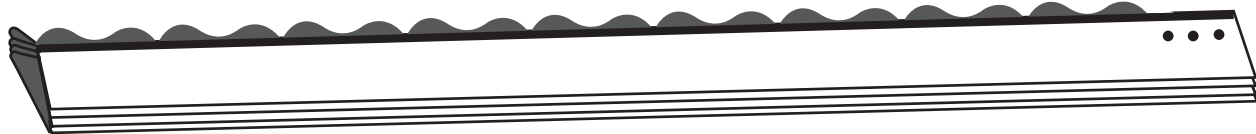

Fan Blade Components

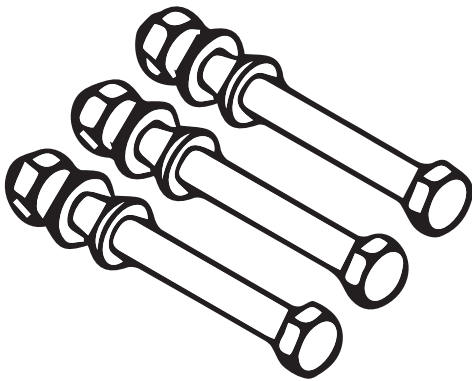

M10X100 Hexagon Screws and Flat/Spring Washers

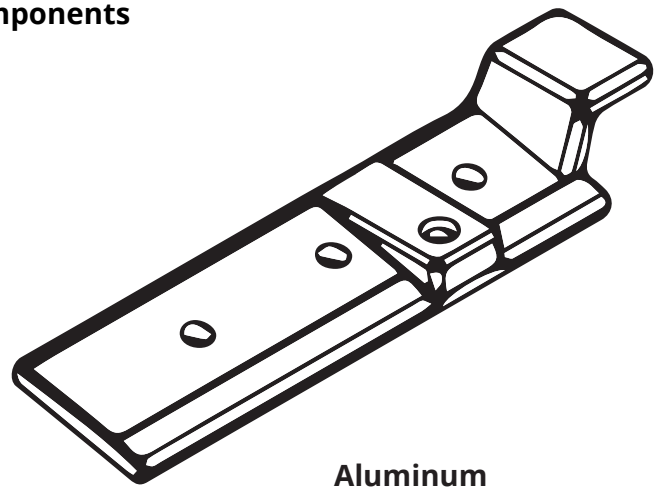

Aluminum Safety Plate

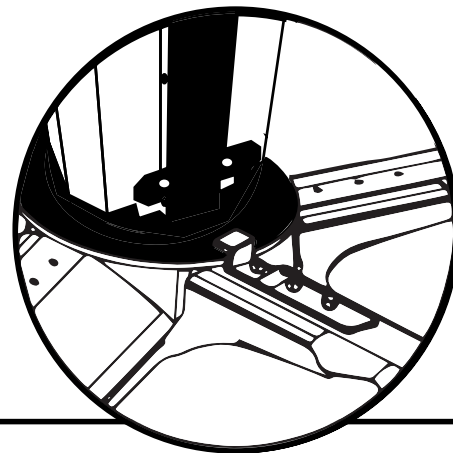
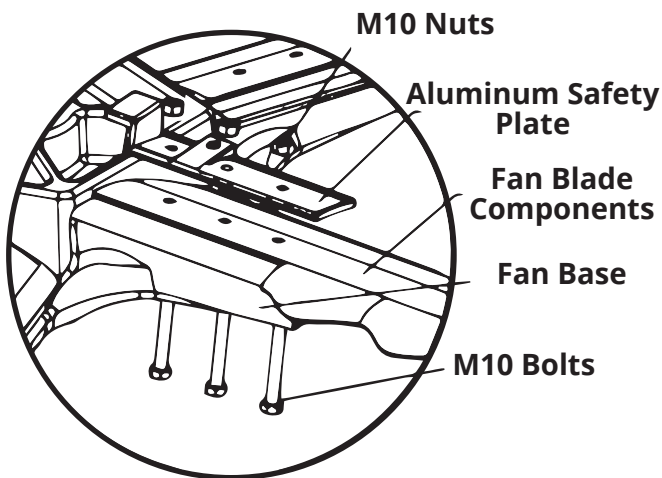

According to the diagram, use the aluminum fan base and safety plate to clamp the fan blade components to the middle position, and then pass through the screws to secure them.

STEP 4

The Arc Plates are installed next to form an additional layer of protection to secure the fan blades to the structure. This step helps to reduce vibration and noise. See the diagram below for proper alignment and installation illustration.

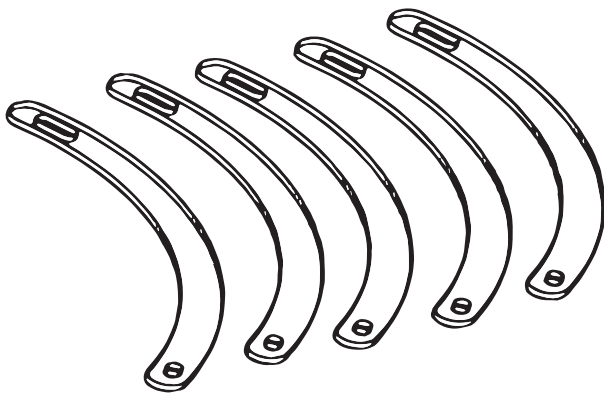

Arc Plates



Bolts, Flat Washers, & Spring Washers

Overlap the arc plates, lining up the holes for the bolts. Tighten the bolts to lock the arc plate onto the safety plate.

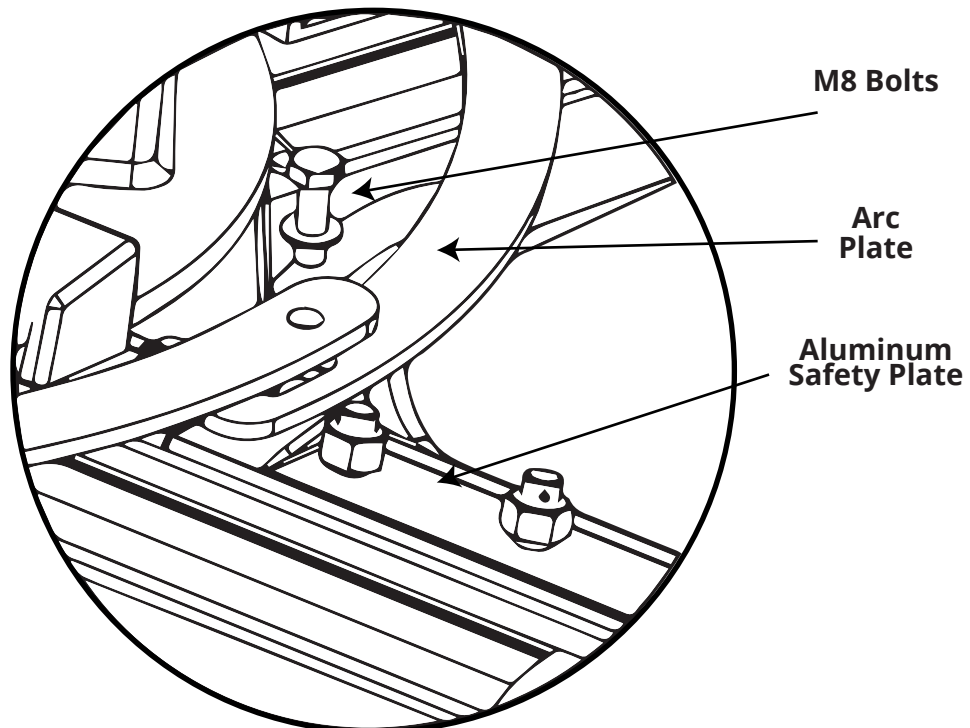

STEP 5

The next step in the installation process includes using the provided wire rope to form an additional safety feature ensuring the fan is secure in the event the fan becomes unsteady due to natural disaster or building structural age. Use the supplied tiger claws to secure the wire rope to the beam. See the diagram below that illustrates proper rope placement.

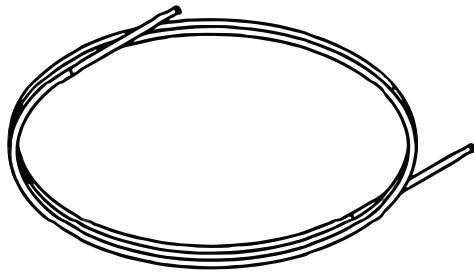

Wire Rope

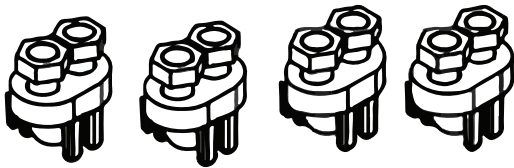

Tiger Claw

According to the diagram, wind the wire rope through the steel-I-beam, and secure it with the tiger claw to lock it in place.

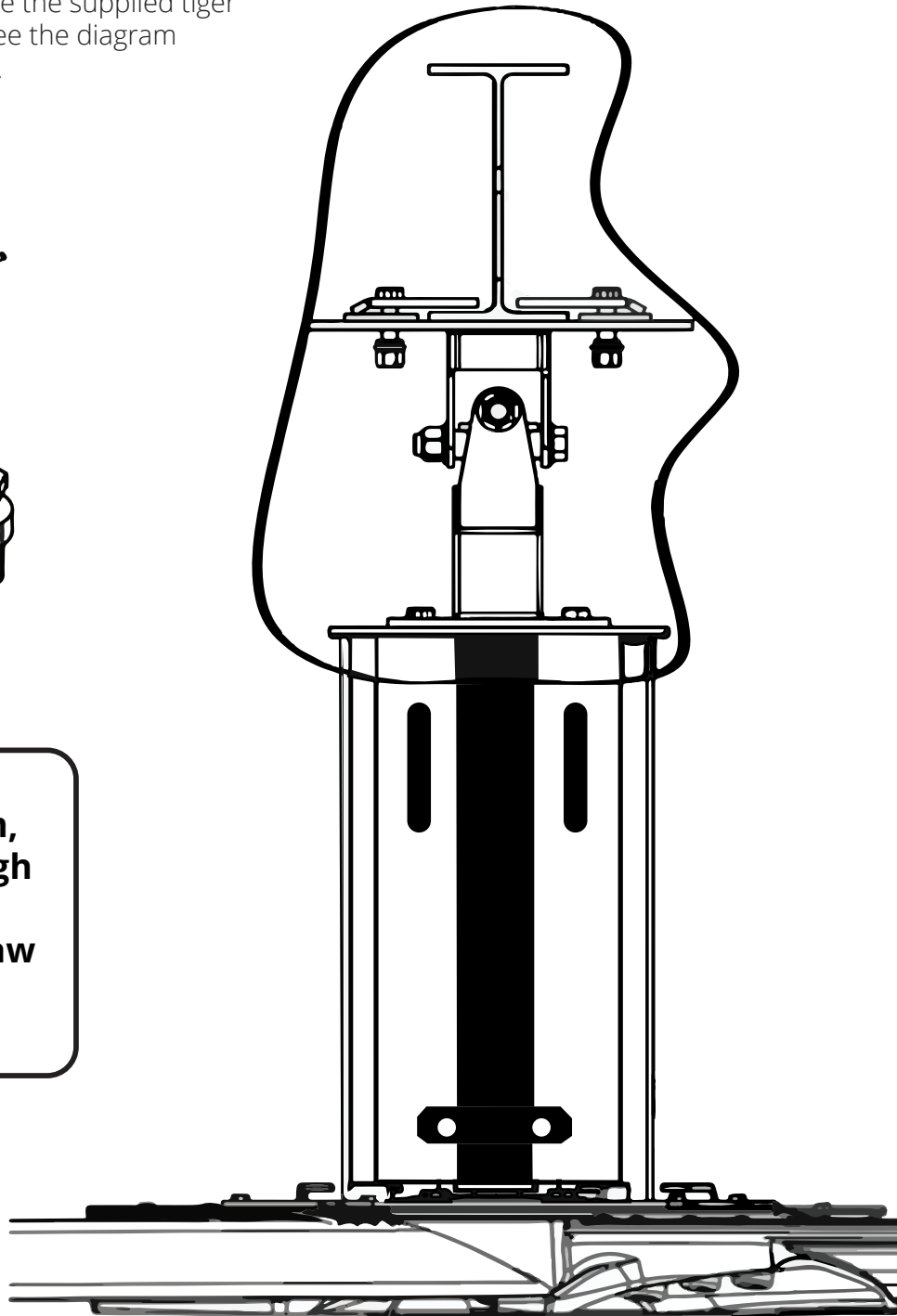

STEP 6

The next step in the installation process includes using the provided wire rope, locks, and tiger claws to stabilize and secure the fan to the building structure. See the diagram below for proper placement using the supplied fan parts identified below.

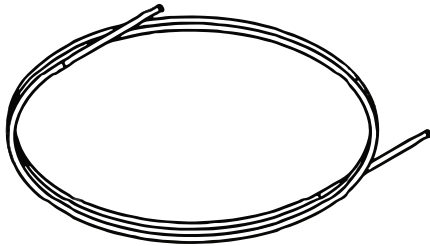

Wire Rope

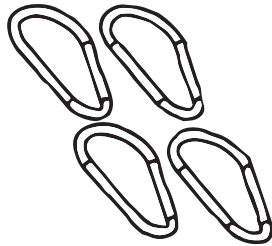

Lock Catch

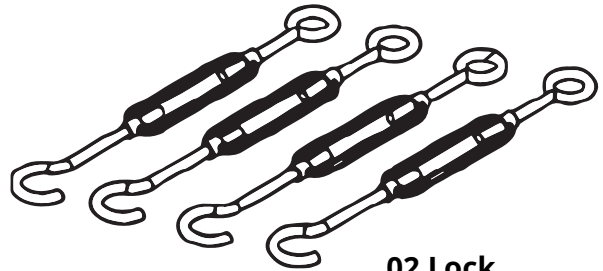

02 Lock

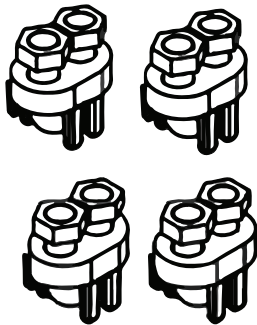

Tiger Claw

Install the wire rope, locks, tiger claws, and lock catches according to the diagram below

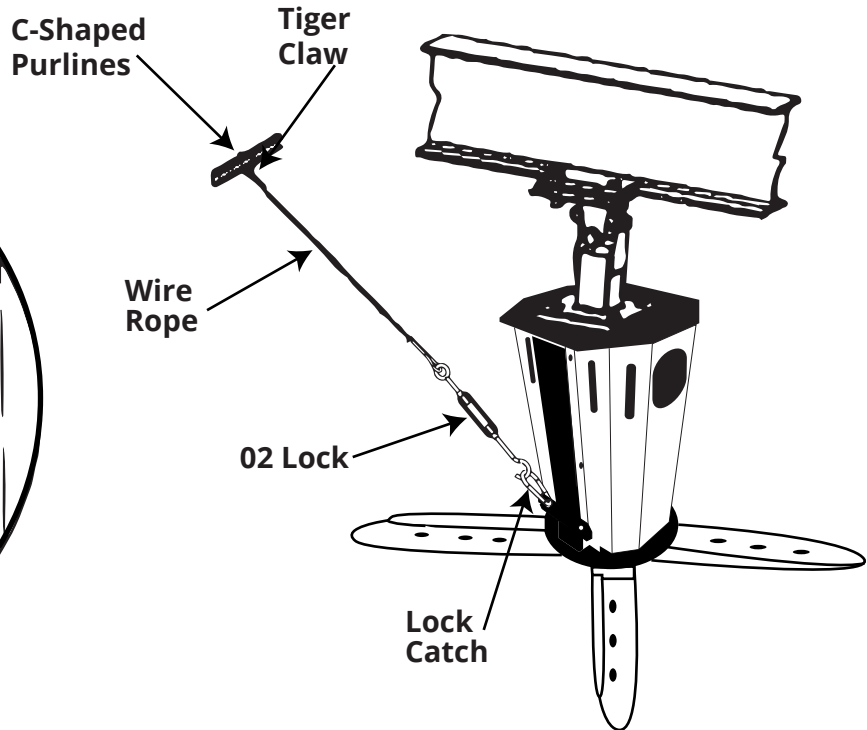
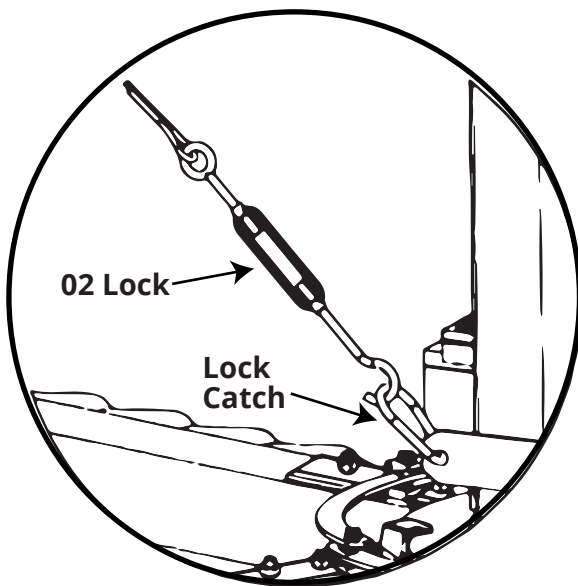

STEP 7

After the fan has been installed and secured to the structure, the final step in the process is to install the Honeywell Control Box to the wall and wire it to the fan motor. Make sure to choose a location that is not accessible to children. The control box is used to operate the HVLS fan, change the fan speed, or change the direction of the fan blades. See the diagrams below and the included Honeywell User Manual for proper installation and wiring procedures.

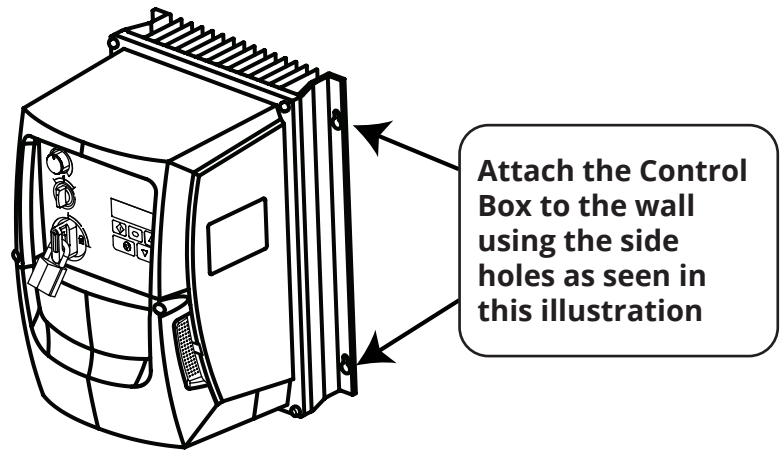

Connection Diagram

Please see the following connection diagrams for power and control wiring. Please refer to the Honeywell User Manual for specific guidelines.

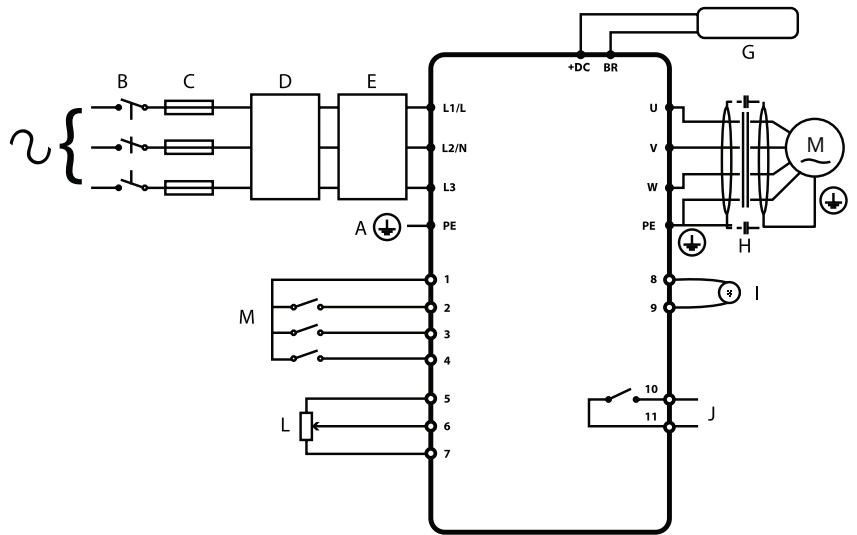

IP20 & IP66 Non-Switched Units

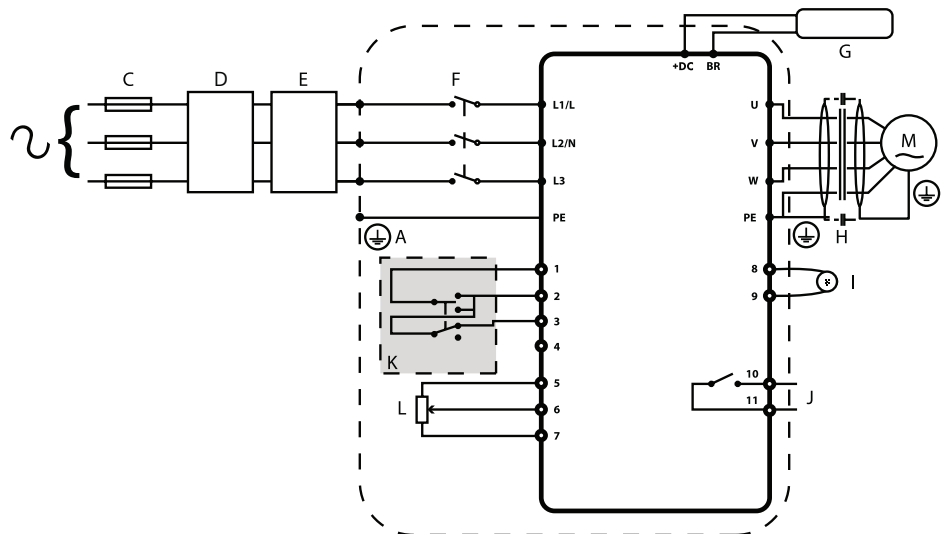

IP66 Switched Units

Key	
A	Protective Earth (PE) Connection
B	Incoming Power Connection
C	Fuse / Circuit Breaker Selection
D	Optional Input Choke
E	Optional External EMC Filter
F	Internal Disconnect / Isolator
G	Optional Brake Resistor
H	Motor Connection
I	Analog Output
J	Relay Output
K	Using the REV/0/FWD Selector Switch (Switched Version Only)
L	Analog Inputs
M	Digital Inputs

Use the control box to operate the fan's speed using the **UP** or **DOWN** keys on the control panel. Any commissioning or fault codes will appear in the display window on the control panel.

NAVIGATE

Used to display real-time information, to access and exit parameter edit mode and to store parameter changes.

UP

Used to increase speed in real-time mode or to increase parameter values in parameter edit mode.

DOWN

Used to decrease speed in real-time mode or to decrease parameter values in parameter edit mode.

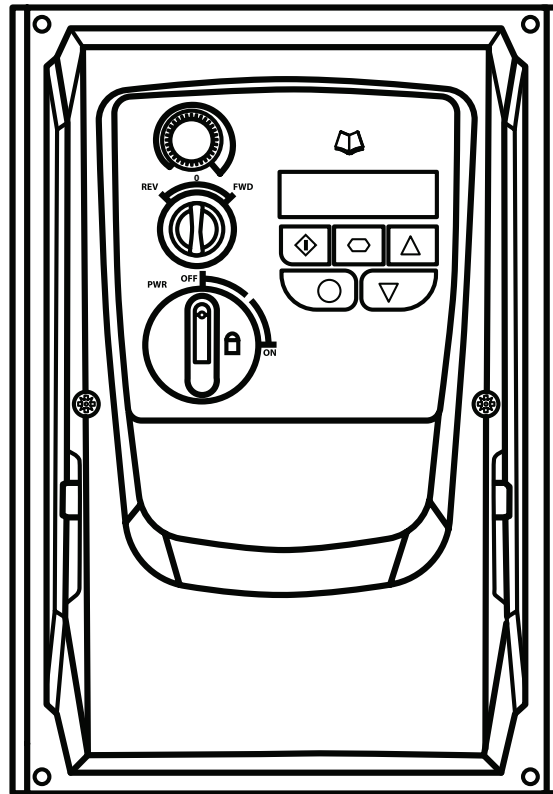

RESET/STOP

Used to reset a tripped drive.

When in Keypad mode is used to Stop a running drive.

START

When in keypad mode, used to Start a stopped drive or to reverse the direction of rotation if bi-directional keypad mode is enabled.

Fan Rotation

The fan blades should rotate counterclockwise as viewed from below the fan. To maximize the energy savings for supplemental heating and cooling systems, operate the fan year-round. The most effective method is listed below.

Heating Season

Set the fan on the slowest speed setting to push the hot air back down from the ceiling without causing a draft. Additionally, lower your thermostat setting by a few degrees to create a comfortable environment while still saving energy costs.

Cooling Season

The fan speed can be adjusted to a higher setting to provide a continuous breeze and constant air movement. By increasing the thermostat's setting by 2-7° and running the fan only when people are present in the building, you can reduce energy costs.

NOTE

Please refer to chapter 5 in the Honeywell Control Box User Manual that is included with your fan for detailed Control Box operation instructions.

Fault Code	No.	Description	Suggested Remedy
no-FLt	00	No Fault	Not required.
B I-b	01	Brake channel over current	Check external brake resistor condition and connection wiring.
BL-br	02	Brake resistor overload	The drive has tripped to prevent damage to the brake resistor.
O- I	03	Output Over Current	Instantaneous Over current on the drive output. Excess load or shock load on the motor. NOTE Following a trip, the drive cannot be immediately reset. A delay time is inbuilt, which allows the power components of the drive time to recover to avoid damage.
I-t-trP	04	Motor Thermal Overload (I2t)	The drive has tripped after delivering >100% of value in P-08 for a period of time to prevent damage to the motor.
O-UoLt	06	Over voltage on DC bus	Check the supply voltage is within the allowed tolerance for the drive. If the fault occurs on deceleration or stopping, increase the deceleration time in P-04 or install a suitable brake resistor and activate the dynamic braking function with P-34.
U-UoLt	07	Under voltage on DC bus	The incoming supply voltage is too low. This trip occurs routinely when power is removed from the drive. If it occurs during running, check the incoming power supply voltage and all components in the power feed line to the drive.
O-t	08	Heatsink over temperature	The drive is too hot. Check the ambient temperature around the drive is within the drive specification. Ensure sufficient cooling air is free to circulate around the drive.
U-t	09	Under temperature	Trip occurs when ambient temperature is less than -10°C. Temperature must be raised over -10°C in order to start the drive.
P-dEF	10	Factory Default parameters loaded	
E-tr ,P	11	External trip	E-trip requested on digital input 3. Normally closed contact has opened for some reason. If motor thermistor is connected check if the motor is too hot.
SC-065	12	Optibus comms loss	Check communication link between drive and external devices. Make sure each drive in the network has its unique address.
FLt-dc	13	DC bus ripple too high	Check incoming supply phases are all present and balanced.
P-L055	14	Input phase loss trip	Check incoming power supply phases are present and balanced.
h O- I	15	Output Over Current	Check for short circuits on the motor and connection cable. NOTE Following a trip, the drive cannot be immediately reset. A delay time is inbuilt, which allows the power components of the drive time to recover to avoid damage.
th-FLt	16	Faulty thermistor on heatsink	
dRtR-F	17	Internal memory fault (IO)	Press the stop key. If the fault persists, consult you supplier.
4-20 F	18	4-20mA Signal Lost	Check the analog input connection(s).
dRtR-E	19	Internal memory fault (DSP)	Press the stop key. If the fault persists, consult you supplier.
F-Ptc	21	Motor PTC thermistor trip	Connected motor thermistor over temperature, check wiring connections and motor
FRn-F	22	Cooling Fan Fault (IP66 only)	Check / replace the cooling fan.
O-hERt	23	Drive internal temperature too high	Drive ambient temperature too high, check adequate cooling air is provided.
OUt-F	26	Output Fault	Indicates a fault on the output of the drive, such as one phase missing, motor phase currents not balanced. Check the motor and connections.
RtF-02	41	Autotune Fault	The motor parameters measured through the autotune are not correct. Check the motor cable and connections for continuity. Check all three phases of the motor are present and balanced.
SC-F0 I	50	Modbus comms loss fault	Check the incoming Modbus RTU connection cable. Check that at least one register is being polled cyclically within the timeout limit set in P-36 Index 3.
SC-F02	51	CAN comms loss trip	Check the incoming CAN connection cable. Check that cyclic communications take place within the timeout limit set in P-36 Index 3.

Note: Following an over current or overload trip (3, 4, 5, 15), the drive may not be reset until the reset time delay has elapsed to prevent damage to the drive.



MIRCOOL®

Cool Blade ~ Because We Blow More™
Industrial HVLS Fan

The design and specifications of this product and/or manual are subject to change without prior notice.
Consult with the sales agency or manufacturer for details.