



Small LED Wall Pack

The EnVision LED 3CCT Small Wall Pack is powerful, waterproof, with a 3CCT select on the 29W fixture: 3000k/4000k/5000k, and a dedicated 40 or 50K on the 60W, and is compatible with universal voltage. It is equipped with a rust-free powder coat, finished with a matte bronze paint, and anti-corrosion priming. With a built-in photocell, easily change which color temperature is being displayed with the flick of a switch.

Applications:

- Outdoor Lighting
- Pathways, Hallways, Entryways

Product Information:

- 3CCT Selectable color temperature
- Small profile with integrated driver
- Integrated dusk to dawn photocell (disconnectable)
- Ideal for building exteriors
- Powder coated rust-free bronze finish
- 5 Year Limited Warranty
- 120-277V



1 Product	2 Wattage/Color	3 Finish	4 Accessories	5 Warranty
LED-WPS Small Wall Pack	29W-TRI 29W (3,800lm) Switchable 30/40/50K 60W-40K 60W (7,860lm) 4000K 60W-50K 60W (7,860lm) 5000K	BZ Bronze (incl.)	(Blank) None PC Photocell (Internal) EMB Emergency Battery Backup (90 Mins. Internal 8W)	(Blank) 5 Year (incl.) 10YR 10 Year

Specs and model numbers are subject to change with or without notice.

FEATURES**Variable Color Temp.**

Switchable 30K/40K/50K color variations available, with the ease of flipping a switch

Aluminum Housing

Die cast aluminum housing, anti-corrosion priming and weatherproof IP67-rated

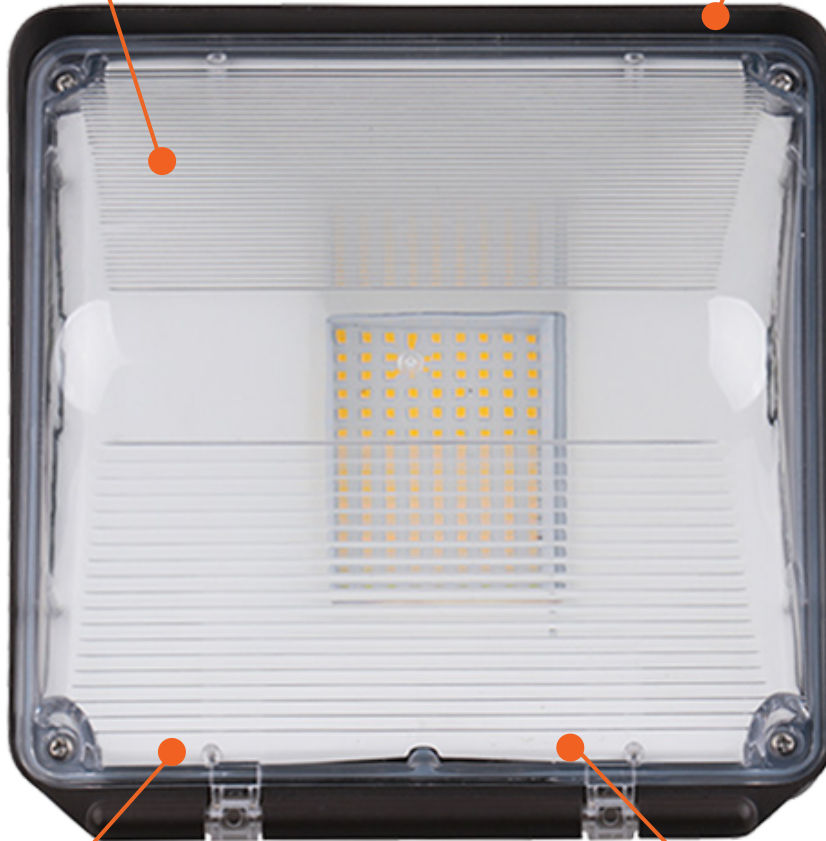
**Built-in Emergency Battery Back-up****Yellowing Free Lens**

Our frosted polycarbonate lens will not turn yellow over time

**Photocell Included**

Pre-installed photocell with daylight detection which turns light on and off

DIMENSIONS

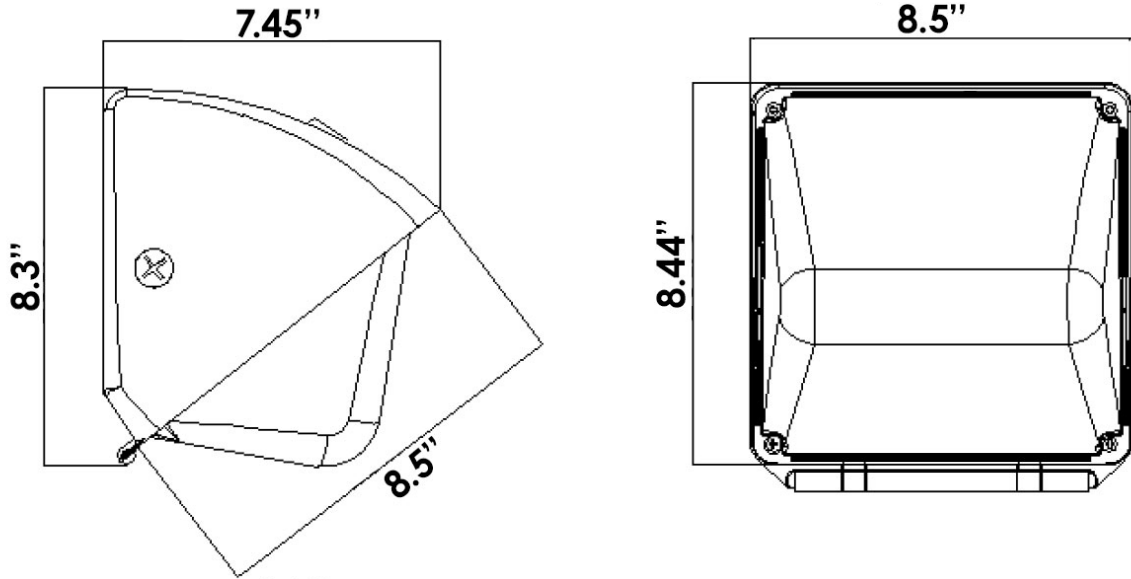

PHOTOMETRICS

