

Project: \_\_\_\_\_  
 Part#: \_\_\_\_\_  
 Type: \_\_\_\_\_

# MR Series Bulbs



The EnVision LED MR16 Bulb in LED brings lighting to the next level. This MR16 bulb is sized to the point it will fit in most fixtures. Use these bulbs with track lights, recessed downlighting, restaurant bar, pub, and cafe lighting. Enjoy watching your energy bills fall, while also saving on replacement costs, as our MR16 is rated 25,000 hours.

**Applications:**

- Track Lights
- Showcases
- Recessed Downlighting
- Restaurants, Bars, Pubs, Cafe Lighting

**Product Information:**

- Increase energy savings and shorten payback period
- High intensity: ready to replace existing 50W halogen
- Same size as traditional MR-16
- Dimmable: With magnetic transformer
- 5 Year Limited Warranty

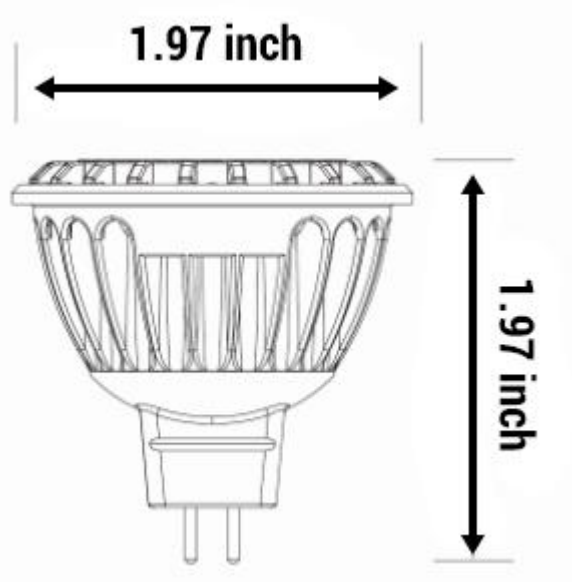

**LED - MR 16 - 5 W - Color - HD - 5 Y R**

1
2
3
4

<b>1</b>	<b>Product</b>	<b>2</b>	<b>Watts</b>	<b>3</b>	<b>Color</b>	<b>4</b>	<b>Warranty</b>
LED-MR16	MR Series Bulbs	5W	5W (350lm)	27K 30K	2700K 3000K	5YR	5 Year (Incl.)

*Specs and model numbers are subject to change with or without notice*