

**embraco**

**UNEK6210Z1**

**MBP-HBP**

**115V**

**134A**

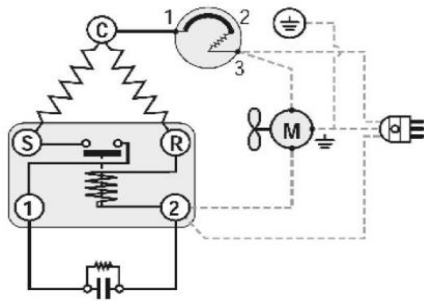

**Wiring Diagram**

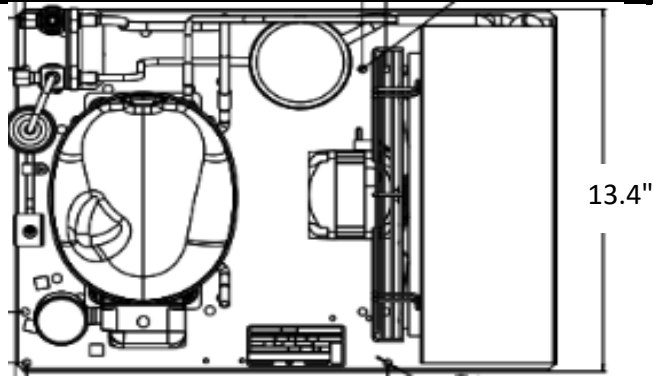

**Weight: 48.2lb**

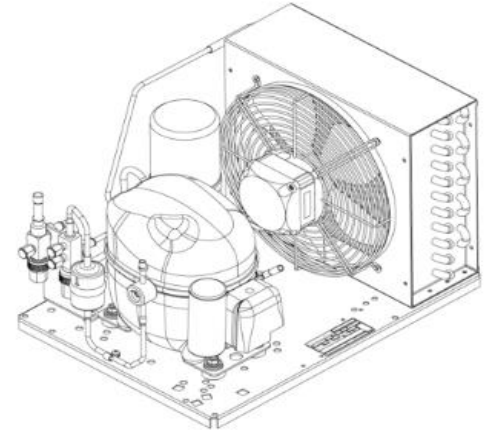
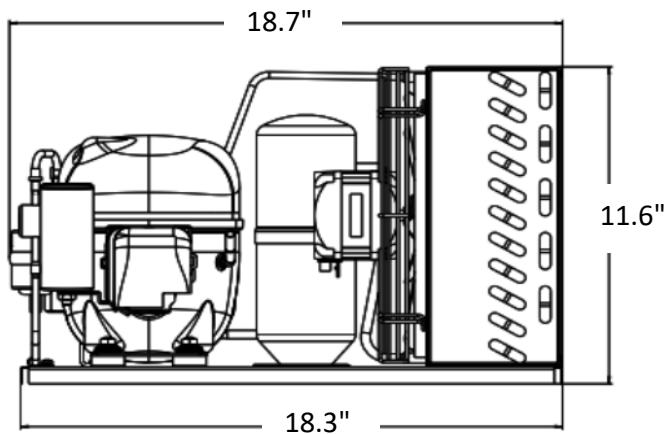

**Technical Specifications**

Rev 03-2017

**Mechanical Data**

|                   |             |
|-------------------|-------------|
| Approximate H.P.  | 1/3+        |
| Starting torque   | HST         |
| Refrigerant       | 134A        |
| Evap. Temp. Range | 5° to 50° F |
| Oil charge        | 11.83 oz.   |
| Oil type          | POE         |
| Viscosity         | ISO22       |

**Electrical Data**

|                                   |           |
|-----------------------------------|-----------|
| <b>Compressor</b>                 | CSIR      |
| Voltage                           | 115/60Hz  |
| Voltage range                     | 103-127V  |
| Run winding resistance at 25° C   | .96 Ω     |
| Start winding resistance at 25° C | 6.1 Ω     |
| Locked rotor current              | 37 amps   |
| RLA: MBP-HBP-60Hz                 | 7.74 amps |

**MBP-Performance-ASHRAE**

|                    |      |
|--------------------|------|
| Temperature - F    | 20   |
| Capacity - BTU/Hr  | 2720 |
| Power - W          | 464  |
| Current - Amps     | 6    |
| Temperature - C    | -6.7 |
| Capacity - Kcal/Hr | 686  |

**Service Parts**

|                              |             |
|------------------------------|-------------|
| Bill of Material             | 558BGL601AA |
| Relay                        | 2283012-ESP |
| Overload                     | 2321020-ESP |
| Start cap 189-227 mfd 250V   | 2252289-ESP |
| Run cap                      | N/A         |
| Condenser fan motor 16W-115V | 1450076     |
| Fan blade D.254/28'/5P       | 2455003     |

**Embraco #**

**HBP-Performance-ASHRAE**

|                    |      |
|--------------------|------|
| Temperature - F    | 45   |
| Capacity - BTU/Hr  | 4437 |
| Power - W          | 630  |
| Current - Amps     | 7.30 |
| Temperature - C    | 7.0  |
| Capacity - Kcal/Hr | 1119 |

|                     |         |
|---------------------|---------|
| Fan Guard           | 2458020 |
| Suction valve-3/8   | 2110060 |
| Discharge valve-1/4 | 2110086 |
| Receiver 1 liter    | 2457034 |

**1610 Satellite Blvd. Suite B, Duluth Ga, 30097 Phone: 678-805-3074**