

**embraco**

UNEK6170Z1

MBP-HBP

115 V

134a

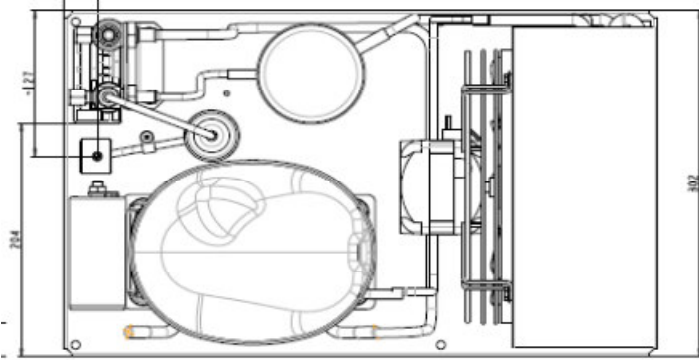
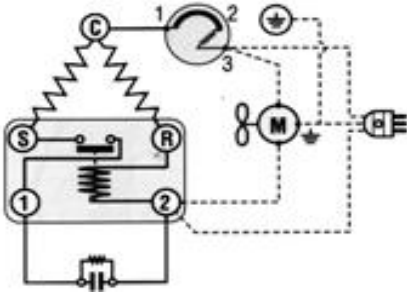

Wiring Diagram

Length: 18.9" Width: 11.9" Height: 10" Weight: 43.9 lb

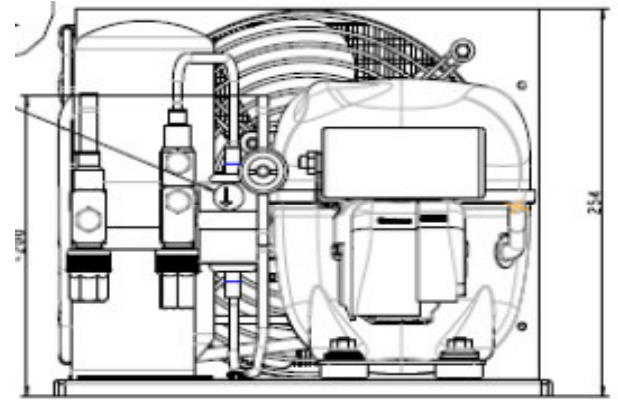
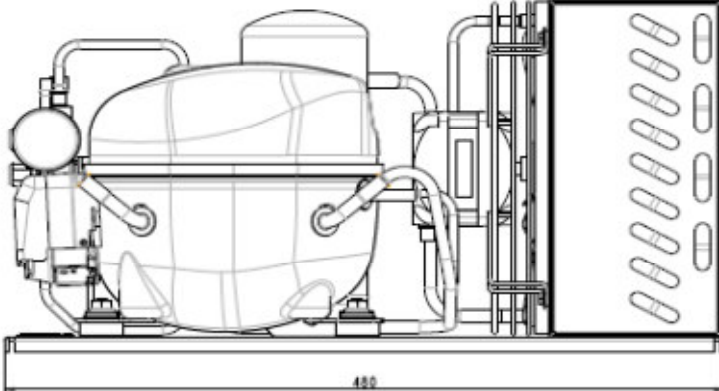

**Technical Specifications**

Rev 5-2016

**Mechanical Data**

**Electrical Data**

Approximate H.P.	1/4+
Starting torque	HST
Refrigerant	134a
Evap. Temp. Range	5° to 50°F
Oil charge	11.84 oz.
Oil type	POE
Viscosity	ISO22

<b>Motor:</b>	CSIR
Voltage	115V / 60 Hz
Voltage range	103-127V
Run winding resistance at 25 °C	1.24 Ω
Start winding resistance at 25 °C	6.14 Ω
Locked rotor current	amps
FLA: M/HBP-60Hz	amps

**MBP-Performance-ASHRAE**

**Service Parts**

**Embraco #**

Temperature - F	20	Bill of Material	573DGL601AA
Capacity - BTU/Hr		Relay MTRPH-0019-31	2271126
Power - W		Overload TO060/J5	2324055
Current - Amps		Start cap 145-174 mfd / 165V	2252318
Temperature - C	-6.7	Condenser fan motor 6W-115V	1450076
Capacity - Kcal/Hr		Fan blade 9"-28°-5B	2455009
		Fan Guard	2458022
Temperature - F	45	Suction valve	2110060
Capacity - BTU/Hr		Discharge valve	2110086
Power - W		Receiver 1 liter	2457034
Current - Amps			
Temperature - C	7.2		
Capacity - Kcal/Hr			

1610 Satellite Blvd. Suite B, Duluth Ga, 30097 Phone: 678-805-3074