

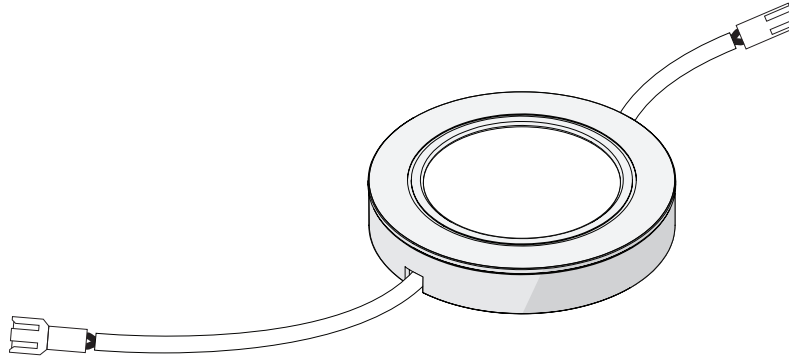

Item # \_\_\_\_\_  
Project \_\_\_\_\_



	12V-SPOT-LK27	12V-SPOT-LK30	12V-SPOT-LK40	12V-SPOT-LK50
<b>Voltage</b>	12VDC			
<b>Wattage</b>	4W			
<b>Lumens</b>	240			
<b>Efficacy</b>	~60 lm/W			
<b>Dimensions</b>	2" (dia.) x .5" (depth)			
<b>Color Temperature</b>	2700	3000	4000	5000
<b>CRI</b>	90+	90+	90+	80+
<b>Max Run</b>	7 Units			
<b>Dimmable</b>	Yes			
<b>Environment*</b>	Damp / Indoor			
<b>Certification</b>	UL Listed			
<b>Warranty</b>	5-Year Warranty			

\*WARNING: NOT FOR USE IN SUBMERSIBLE APPLICATIONS

**SKU Builder**

DI

-

12V

-

SPOT

-

LK

--

Voltage

Spotmod

Link

CCT

Finish

27	WH	(White)
30	BL	(Black)
40	AL	(Aluminum)
50	BR	(Bronze)

Example: DI-12V-SPOT-LK30-BR = Diode, 12 Volt, SPOTMOD<sup>®</sup> LINK, 3,000° CCT, with Bronze finish.

## SPECIFICATIONS

- Mounting: Surface or Recessed
- Ambient Temp<sup>1</sup>: -4 - 122°F (-20 ~ 50°C)
- Operating Temp<sup>2</sup>: -4 - 176°F (-20 ~ 80°C)

## COMPLIANCE & REGULATORY APPROVALS

### Safety

- UL Listed 2108. UL 1598 / CSA 250.0-08, UL 8750. UL 879 / CAN/CSA-C22.2 no. 207-M89. E469769 (UL Listed), E469770 (SAMS Manual).

### INCLUDED ACCESSORIES

- A. (2) Mounting Screws



## ADDITIONAL ACCESSORIES

ITEM #	DESCRIPTION	
DI-SPOT-LK-ADP	SPOTMOD LINK 1ft. 2-pin (male) to DC (female) Adapter Cable Dimensions: 12 x 0.45 in. (L x Dia) Color: White	
DI-SPOT-5EXT	SPOTMOD TILE and LINK 5 ft 2-pin male to female Extension Cable Dimensions: 60 x .25 x .25 in. (L x W x H) Color: White	

## MECHANICAL DIAGRAMS

SPOTMOD® LINK  
DI-12V-SPOT-LK

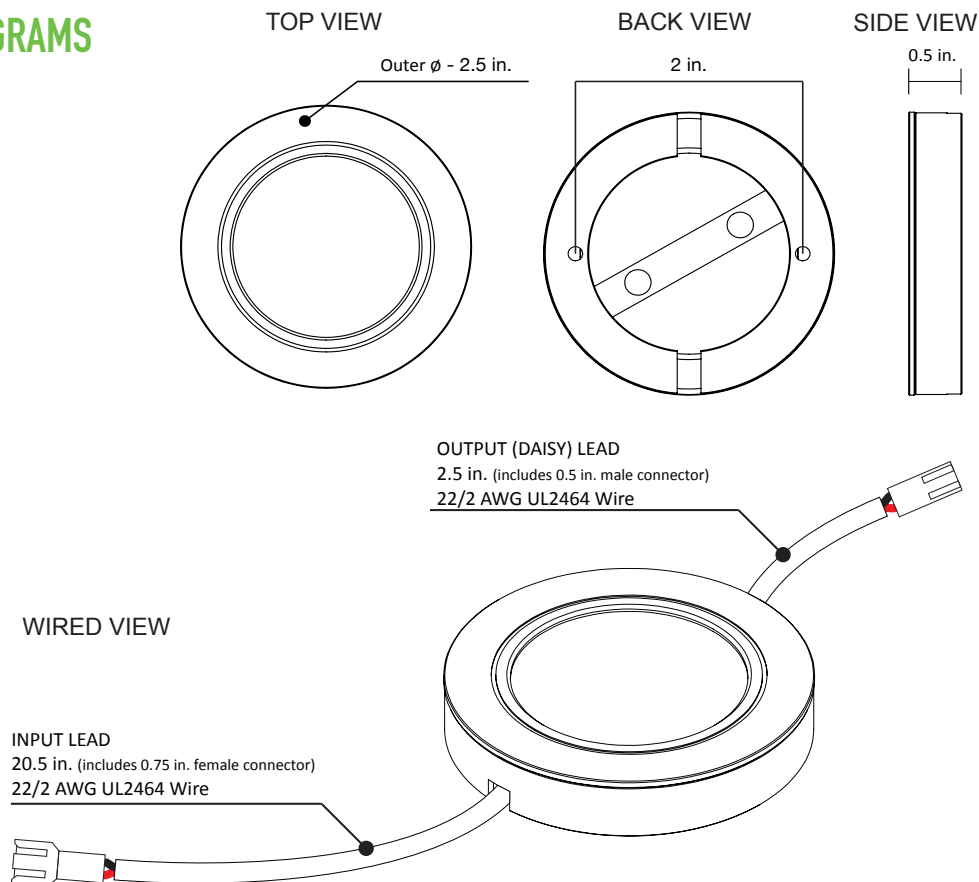

1. Do not install product in an environment outside the listed ambient temperature. Exceeding the maximum ambient temperature may damage LED chips, reduce the total lamp life, lumen output, and/or adversely impact color consistency.
2. Operating temperature is measured according to the minimum and maximum ambient temperature environment.

## MECHANICAL DIAGRAMS (CONT.)

### EXPLODED VIEW

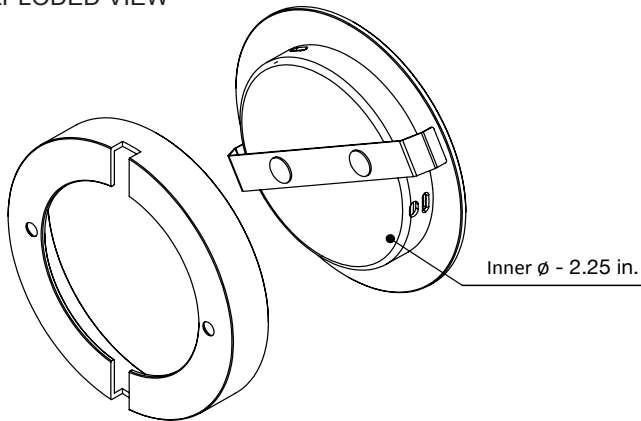

## ADDITIONAL INFORMATION

- SPOTMOD® LINK Installation Guide

## SAFETY / WARNINGS / DISCLOSURES

1. Install in accordance with national and local electrical code regulations.
2. This product is intended to be installed and serviced by a qualified, licensed electrician.
3. Not for use in or on walls of pools, fountains, or other partially or fully submersed locations.
4. Do not modify or disassemble product beyond instructions or this warranty will be void.
5. Actual color may vary from what is pictured above and on other print materials due to the limitations of photographic processes.
6. We reserve the right to modify and improve the design of our fixtures without prior notice. We cannot guarantee to match existing installed fixtures for subsequent orders or replacements in regards to product appearance, CCT, or lumen output.

## WARRANTY

### Limited Warranty

This product has a five (5) year limited warranty from the date of shipment. This warranty does not include the additional accessories referenced in this specification sheet. Complete warranty details for fixtures and additional accessories are available at [www.diodeled.com/limited-warranty/](http://www.diodeled.com/limited-warranty/) within the Policies section. For warranty related questions please contact product support.

### Consumer's Acknowledgment

Elemental LED, Inc. stands behind its products when they are used properly and according to our specifications. By purchasing our products, the purchaser agrees and acknowledges that lighting design, configuration and installation is a complex process, wherein seemingly minor factors or changes in layout and infield adjustments can have a significant impact on an entire system. Choosing the correct components is essential. Elemental LED is able to work with the original purchaser to make an appropriate product selection to the extent of the limited information that the customer can provide, but it is virtually impossible for Elemental LED to design a system that foresees every unknown factor. For this reason, this Warranty does not cover problems caused by improper design, configuration or installation issues. Any statement from an Elemental LED employee or agent regarding a customer's bill of goods and/or purchase order is NOT an acknowledgment that the products purchased are designed and configured correctly. The purchaser agrees and acknowledges that it is the customer's responsibility to adhere strictly to all information contained in the Product Specification Sheets.

There is often more than one way to design, configure and layout an LED lighting application properly to achieve the same lighting effect. Elemental LED strongly recommends that licensed professionals be used in the design and installation of lighting systems that include Elemental LED products. The specifications include important information that a designer and installer should carefully review and strictly follow. Qualified designers and certified and/or licensed installers, with access to the final installation environment, customer goals, and Elemental LED product specifications can make the requisite decisions appropriate for a successful finished lighting application.