

GM5100

POST FIXTURE

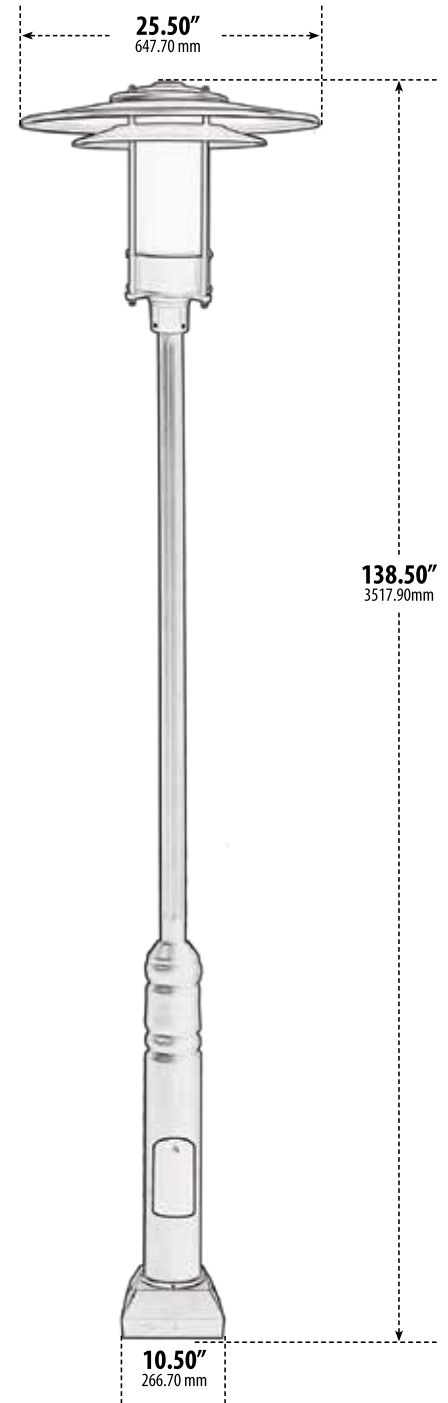
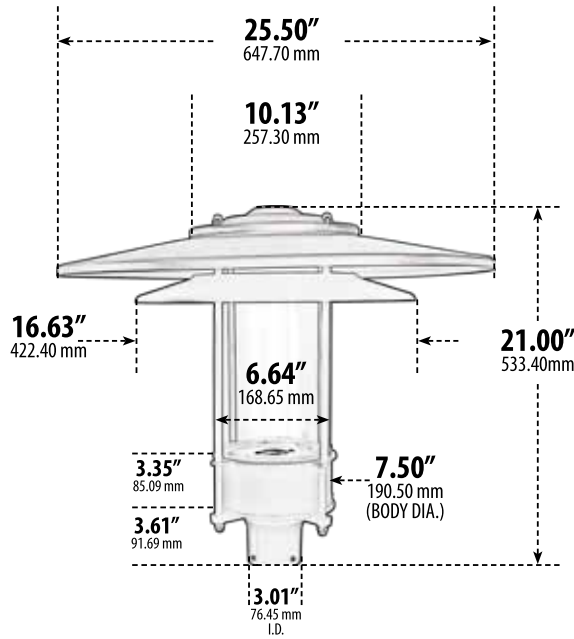

- ▶ **Material:** Powder Coated Cast Aluminum
- ▶ **Lens:** Clear, Heat Resistant, Tempered Glass
- ▶ **Available Finish:** Black, Verde Green
- ▶ **ETL Approval Pending**

| MODEL NUMBER | LAMP TYPE | ILLUMINANT TYPE | WATTS (W) | VOLTS (V) | LAMP(S) INCLUDED? |
|--------------|-------------|-----------------|-----------|-----------|-------------------|
| GM5100 | A-Type | Incandescent | 60 | 120 | NO |
| GM5100-LED20 | G24-LED | LED | 20 | 120-277 | YES |
| GM5100-LED30 | Tubular LED | LED | 30 | 85-265 | YES |

20W LED Available in 30K or 50K
 30W LED Available in 30K or 65K

Overall Dimensions:
 138.50"H x 25.50"W x 25.50"D

Weight: 85.42 lbs
 Approximate Wire Length: N/A

DABMAR
 LIGHTING

DABMAR LIGHTING INCORPORATED

320 Graves Ave . Oxnard, CA 93030 . 805.604.9090 . f: 805.604.9050 . www.dabmar.com
 4693 19th Street Ct E . Bradenton, FL 34203