

BS250

PIER MOUNTS FOR POST TOP FIXTURES

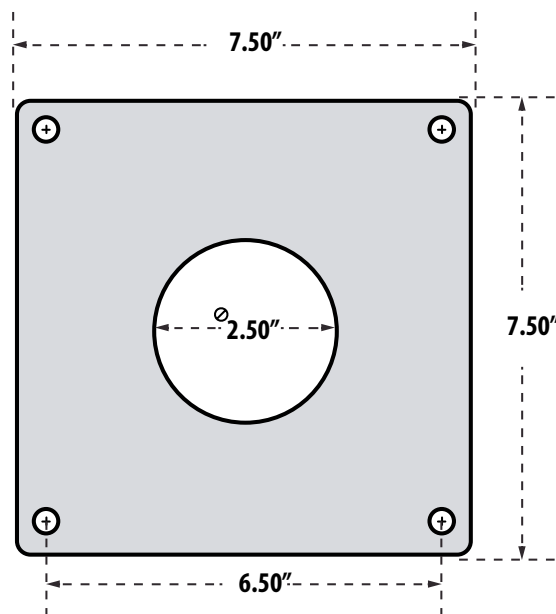

- ▶ **Material:** Powder Coated Cast Aluminum
- ▶ **Available Finish:** Black, White, Bronze, Verde Green

MODEL NUMBER		
BS250	7¼"H x 7½"W BASE	3" OD FITTER

Overall Dimensions:
7.38"H x 7.50"W x 7.50"D

Weight: 3.8 lbs
Box Dimensions: 7.75"H x 8.00"W x 8.00"D

DABMAR
LIGHTING

DABMAR LIGHTING INCORPORATED

320 Graves Ave . Oxnard, CA 93030 . 805.604.9090 . f: 805.604.9050 . www.dabmar.com
4693 19th Street Ct E . Bradenton, FL 34203